



FOCUS ON IMPROVEMENT
PROFESSIONAL IN SERVICES

3S/3E series

SINGLE-STAGE END SUCTION PUMP



COMPANY PROFILE

MARO is a high-tech enterprise integrating research and development, production, sales and service. Factory located in Shanghai Bay High-tech Industrial Zone.

We are committed to the development and manufacturing of special motor industry, the main motors are YE3, YE4 series of high-efficiency three-phase asynchronous motors; YPT3 series variable frequency speed regulating three-phase asynchronous motor; YBX3, YBX4 series high efficiency explosive proof three-phase asynchronous motor, YBBPX3 series explosive proof variable frequency speed regulation three-phase asynchronous motor and other products, the company has passed the ISO9001 quality management system certification, explosion-proof electrical equipment has passed the CCC product certification, explosion-proof motor certificate and many other national departments issued the certification certificate. The company has introduced advanced equipment and technology at home and abroad, and has gained good reputation in the same industry with scientific design, precision processing and rigorous testing.

Adhering to the business philosophy of "focus on improvement, professional in service" and implementing the values of pragmatic work style and concept of integrity and responsibility, we provide high-quality products to establish win-win business relationship with all customers.

CONTENTS

Product introduction	01
Schematic diagram of product structure	02
Application scope	03
Technical parameter	03
Part material list	03
Mechanical seal type selection table	04
Model definition	04
Type spectrogram	05
Performance parameter table	07
Performance curve	17
Installation dimension	38
Installation and maintenance	50

Brief introduction



3S series horizontal close-couple pump



3E series horizontal coupling pump

The 3S/3E series end-suction pump was developed by YIMAN group as a new generation product, benefit from platform thinking, the product own following advantage:

- Professional appearance of family design
- Hydraulic layout optimized to fit market trend, interchangeable with top brands
- By apply CFD in design process, hydraulic efficiency reach energy conservation level according to GB19762-2007
- Full 3d design, FEA is involved to ensure a optimized structure and strength
- Prolonged motor shaft provide the chance of reducing complexity and gain high reliability on 3S series pump
- Different bearing bracket could be apply to same pump due to modularized design of 3E series pump
- YX3(IE3) motor as standard offer, contribute to energy conservation and environment protection
- High component commonality with IL series gives a good serviceability and economy

Explosive view :

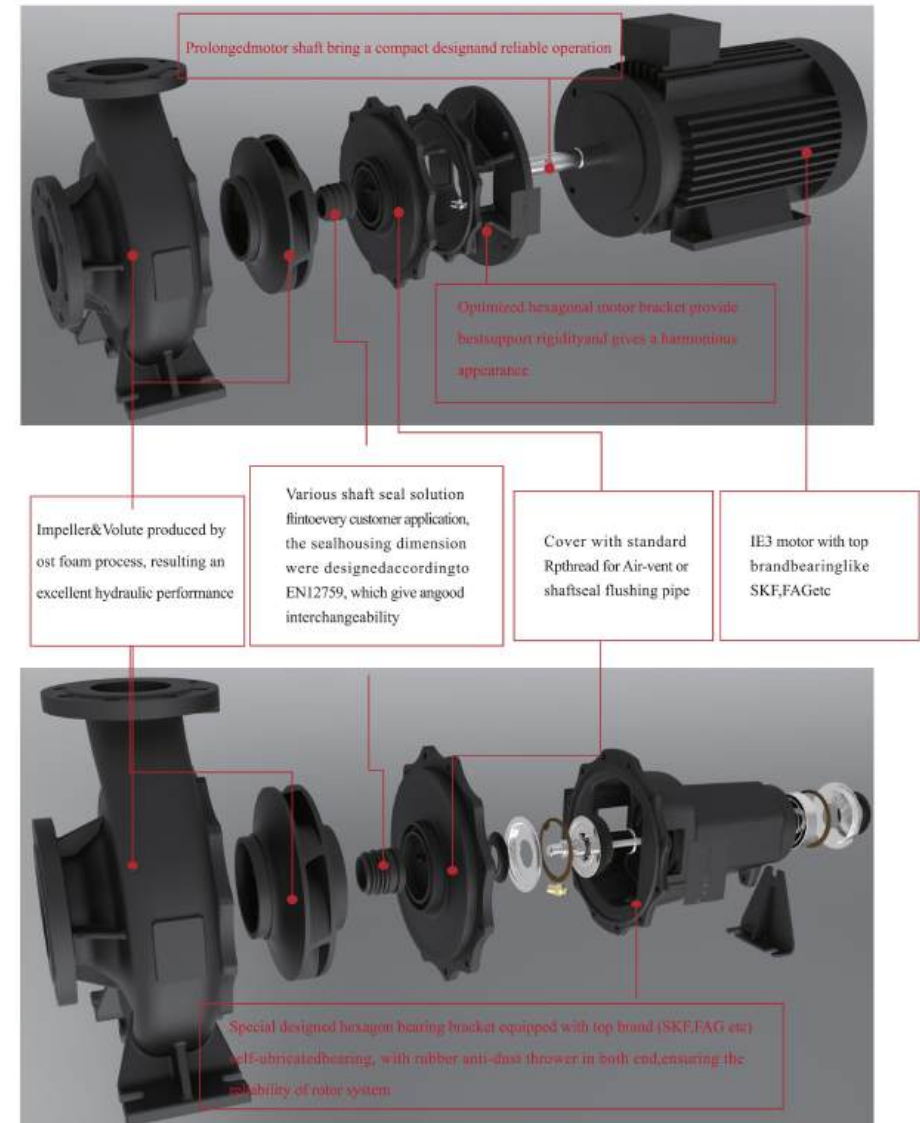

Application

- District heating and air conditioning system
- Cooling system
- Commercial building water supply
- Other light chemical process

Technical data :

	2 Pole	4 Pole
Flow	Max to 400m ³ /h / Up to 400m ³ /h	Max to 1200m ³ /h / Up to 1200m ³ /h
Head	Max to 150m / Up to 150m	Max to 90m / Up to 90m
Media temperature	-25~140°C (For details refer to shaft seal selecting sheet)	
Pressure rating	10bar for standard version, 16bar, 25bar available as customer required	
Connection	DN50-DN300,dimensions apply to EN 1092-2 and GB/T 17241.6	
Pumping media	Clean,low viscosity water-like liquid without particle or fibers inside	

Component Material:

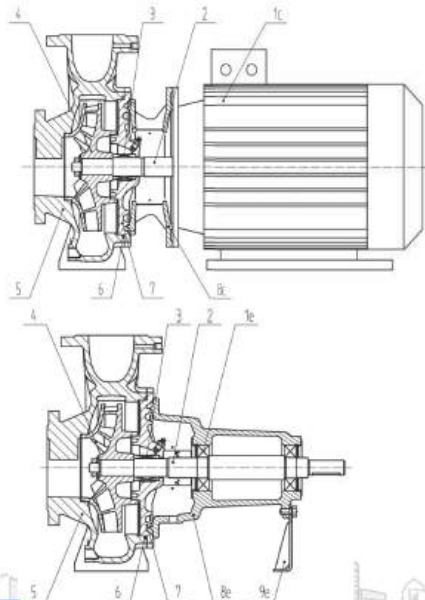

POS	Description	Material	
		standard	option
1c	Motor	YE3high efficiency motor	others
1e	Bearing	maintenance-free bearing	SKF, NSK
2	Shaft	45#	2Cr13
3	Shaft seal	Standard graphite silicon carbide +EPDM	refer to selection sheet
4	Impeller	HT200	QT450, 304
5	Housing	HT250	QT450, 304
6	O-ring	EPDM	FKM/Viton
7	Cover	HT250	V450, 304
8c	Motor bracket	HT250	QT450, 304
8e	Bearing bracke	HT200	
9e	Bracket foot	45#	

M/S selection:

Pumping media	Temperature	Rot. Ring mat.	Sta. Ring mat.	Secondary seal	Remark
Low temp.water	0~120°C	Carbon	SiC	EPDM	Standard
High temp.water	120~140°C	Carbon	WC	EPDM	Optional
Coolant	-25~90°C	SiC	SiC	EPDM	Optional
Oil	-90°C	SiC	SiC	FKM/Viton	Optional

Model Definition:

3S/3E SINGLE-STAGE END SUCTION PUMPS

3S/3E 150-125-250/A/B

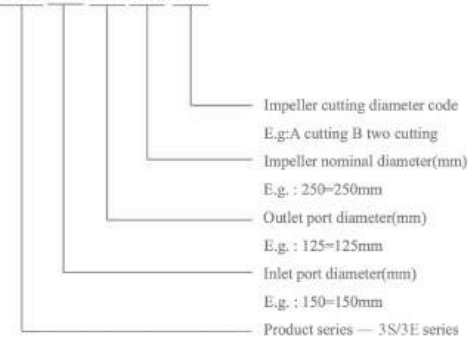

Hydraulic layout

50Hz 4-pole motor

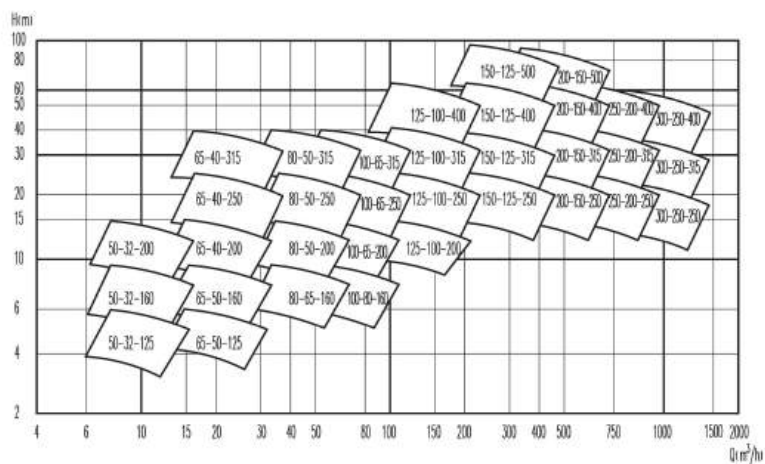

50Hz 2-pole motor

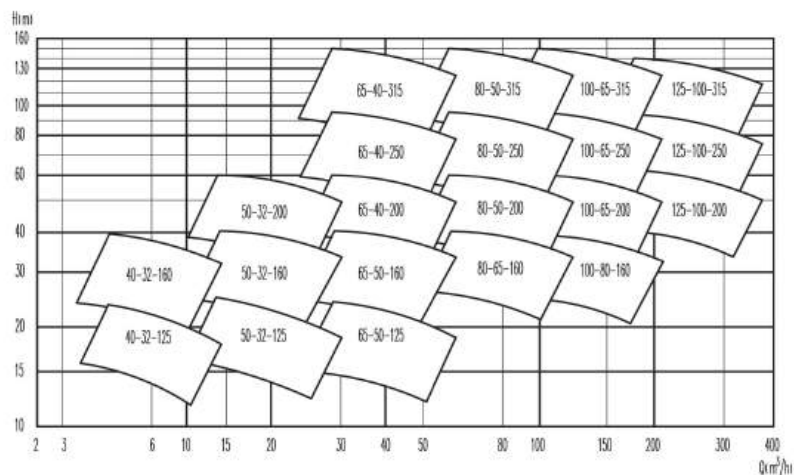

Curve condition

The following conditions are suitable for the performance curves shown:

1. Curve tolerance is conformity with ISO 9906, Annex A;
2. All curves are based on the measured value of magnet $3 \times 380V$, under the constant speed of 2900 rpm, 1450 rpm or 1480 rpm;
3. Measurements is done with $20^{\circ}C$, air-free water, without impurities, kinematic viscosity of $1 \text{ mm}^2/\text{s}$ (1cSt) ;
4. If the thickness and density of the pumped liquid is different from water, the motor power should be adjusted.
5. The NPSHr curve of the candidate pump type corresponds the biggest impeller diameter, the NPSHr value should be added a minimum safety margin of 0.5 m.

Performance data sheet
50Hz4-pole motor

S/N	Model	Flow rate (m ³ /h)	Head (m)	Motor power (kw)	Rated speed (r/min)	NPSH (m)
1	50-32-200	8.8	15.1	1.1	1450	1.5
		12.5	14			
		16.3	12.1			
2	50-32-200A	8.0	13.5	0.75	1450	1.5
		11.5	12			
		15.0	10.2			
3	50-32-200B	7.5	12.5	0.75	1450	1.5
		10.5	11			
		13.7	9.5			
4	65-50-160	17.5	9.9	1.1	1450	1.5
		25	9			
		32.5	8			
5	65-50-160A	16.4	7.8	1.1	1450	1.8
		23.5	7			
		30.5	6			
6	65-50-160B	13	6.2	0.75	1450	1.8
		21.5	5.5			
		28	4.5			
7	65-40-200	17.5	15.4	2.2	1450	1.5
		25	14			
		32.5	12.4			
8	65-40-200A	16.4	13.2	1.5	1450	1.8
		23.5	12			
		30.5	10.5			
9	65-40-200B	13	11.1	1.1	1450	1.8
		21.5	10			
		28	8.6			
10	65-40-250	17.5	23.5	3.0	1450	1.6
		25	22			
		32.5	20			
11	65-40-250A	14	20.1	2.2	1450	1.8
		23.5	18			
		30.5	15.9			
12	65-40-250B	13	17.5	2.2	1450	1.8
		21.5	16			
		28	14.3			
13	65-40-315	17.5	37.5	5.5	1450	1.6
		25	36			
		32.5	32			

Performance data sheet
50Hz4-pole motor

S/N	Model	Flow rate (m ³ /h)	Head (m)	Motor power (kw)	NPSH (m)
14	65-40-315A	16.4	33.5	5.5	1.8
		23.5	32		
		30.5	28.2		
15	65-40-315B	13	29.5	4.0	1.8
		21.5	28		
		28	24.2		
16	80-65-160	35	9.8	2.2	2.0
		50	9		
		65	8		
17	80-65-160A	32.5	7.7	1.5	2.2
		46.5	7		
		60.5	6.1		
18	80-65-160B	31	6.2	1.1	2.2
		44.5	5.5		
		58	4.3		
19	80-50-200	35	15	3.0	2.0
		50	14		
		65	12.2		
20	80-50-200A	32.5	13	3.0	2.2
		46.5	12		
		60.5	10		
21	80-50-200B	31	11	2.2	2.2
		44.5	10		
		58	8.6		
22	80-50-250	35	23.5	5.5	2.0
		50	22		
		65	20.2		
23	80-50-250A	32.5	21.8	5.5	2.2
		46.5	20		
		60.5	17.5		
24	80-50-250B	31	19.6	4.0	2.2
		44.5	18		
		58	15.8		
25	80-50-315	35	37.2	11	2.0
		50	35		
		65	32		
26	80-50-315A	32.5	32.5	7.5	2.2
		46.5	30		
		60.5	27.2		

Performance data sheet
50Hz4-pole motor

S/N	Model	Flow rate (m ³ /h)	Head (m)	Motor power (kw)	NPSH (m)
27	80-50-315B	31	26.2	5.5	2.2
		44.5	24		
		58	21.4		
28	100-80-160	56	9.9	3.0	2.3
		80	9		
		104	7.8		
29	100-80-160A	53.2	8.5	3.0	2.5
		76	7.5		
		98.8	6.3		
30	100-80-160B	50.8	6.9	2.2	2.5
		72.5	6		
		94.3	4.8		
31	100-65-200	56	15.2	5.5	2.3
		80	14		
		104	12.2		
32	100-65-200A	53.2	13.2	4.0	2.5
		76	12		
		98.8	10.1		
33	100-65-200B	50.8	11.2	3.0	2.5
		72.5	10		
		94.3	7.8		
34	100-65-250	56	23.8	7.5	2.3
		80	22		
		104	20.2		
35	100-65-250A	53.2	21.7	7.5	2.5
		76	20		
		98.8	17.5		
36	100-65-250B	50.8	17.5	5.5	2.5
		72.5	16		
		94.3	13.5		
37	100-65-315	56	37	15	2.3
		80	35		
		104	32		
38	100-65-315A	53.2	32.5	11	2.5
		76	30		
		98.8	25.5		
39	100-65-315B	50.8	25.5	7.5	2.5
		72.5	23		
		94.3	18.5		

Performance data sheet
50Hz4-pole motor

S/N	Model	Flow rate (m ³ /h)	Head (m)	Motor power (kw)	NPSH (m)
40	125-100-200	105	15.7	11	2.5
		150	14		
		195	11.6		
41	125-100-200A	98	13.7	7.5	2.8
		140	12		
		182	9.6		
42	125-100-200B	91	11.6	5.5	2.8
		130	10		
		169	8		
43	125-100-250	105	24.5	15	2.5
		150	22		
		195	18.8		
44	125-100-250A	98	22.5	15	2.8
		140	20		
		182	16.5		
45	125-100-250B	91	19.5	11	2.8
		130	18		
		169	14.8		
46	125-100-315	105	38.2	22	2.5
		150	35		
		195	30.5		
47	125-100-315A	98	34.2	18.5	2.8
		140	30		
		182	25.5		
48	125-100-315B	91	28.5	15	2.8
		130	25		
		169	20.5		
49	125-100-315S	80	38.2	18.5	3.0
		115	35		
		150	30.5		
50	125-100-315SA	77	36.2	15	3.0
		100	32		
		130	27.5		
51	125-100-400	105	59.5	37	2.5
		150	56		
		195	48.5		
52	125-100-400A	98	51.5	30	2.8
		140	48		
		182	40.5		

Performance data sheet
50Hz4-pole motor

S/N	Model	Flow rate (m ³ /h)	Head (m)	Motor power (kw)	NPSH (m)
53	125-100-400B	91	41.5	22	2.8
		130	38		
		169	30.5		
54	125-100-400S	80	59.5	30	3.0
		115	56		
		150	48.5		
55	125-100-400SA	77	53.5	22	3.0
		100	50		
		130	42.5		
56	150-125-250	210	24.8	30	3.2
		300	22		
		390	19		
57	150-125-250A	192	22.8	22	3.5
		275	20		
		358	16.4		
58	150-125-250B	175	18.5	18.5	3.5
		250	16		
		325	12.5		
59	150-125-315	210	38.5	45	3.2
		300	35		
		390	30.5		
60	150-125-315A	192	33.5	37	3.5
		275	30		
		358	25.5		
61	150-125-315B	175	28.5	30	3.5
		250	25		
		325	20.5		
62	150-125-315S	150	38.5	37	3.5
		220	35		
		285	30.5		
63	150-125-315SA	140	35.5	30	3.5
		200	32		
		260	27.5		
64	150-125-400	210	62.6	75	3.2
		300	56		
		390	50.5		
65	150-125-400A	192	56.6	55	3.5
		275	50		
		358	44.2		

Performance data sheet
50Hz4-pole motor

S/N	Model	Flow rate (m ³ /h)	Head (m)	Motor power (kw)	NPSH (m)
66	150-125-400B	175	48.5	45	3.5
		250	42		
		325	38.6		
67	150-125-400S	150	62.6	55	3.8
		220	56		
		285	49.5		
68	150-125-400S (A)	140	50.2	45	3.8
		200	50		
		260	42.5		
69	200-150-250	350	23.5	45	5.5
		500	20		
		600	15		
70	200-150-250A	315	21.5	37	5.8
		450	18		
		540	13		
71	200-150-315	350	39.4	75	5.5
		500	35		
		600	30.2		
72	200-150-315A	315	33.5	55	5.8
		450	30		
		540	24.8		
73	200-150-315B	280	27.6	45	5.8
		400	25		
		480	20.3		
74	200-150-315S	280	39	55	5.8
		400	35		
		480	30		
75	200-150-315SA	260	33.5	45	5.8
		375	30		
		450	25		
76	200-150-400	350	61	110	5.5
		500	56		
		600	49.5		
77	200-150-400A	315	55	90	5.8
		450	50		
		540	43.5		
78	200-150-400B	280	50.5	75	5.8
		400	45		
		480	38.5		

Performance data sheet

50Hz4-pole motor

S/N	Model	Flow rate (m ³ /h)	Head (m)	Motor power (kw)	NPSH (m)
79	200-150-400S	280	60	90	5.8
		400	56		
		480	50.5		
80	200-150-400SA	260	55	75	5.8
		375	50		
		450	43.5		
81	200-150-500	350	91.5	200	5.3
		500	85		
		600	76		
82	200-150-500A	315	86	160	5.3
		450	80		
		540	71		
83	200-150-500B	280	81	132	5.3
		400	75		
		480	67		
84	250-200-250	500	24.5	55	6.5
		720	20		
		860	17		
85	250-200-250A	420	19.5	45	6.5
		600	17		
		720	14		
86	250-200-315	525	38	90	6.5
		750	32		
		900	30		
87	250-200-315A	455	33	75	7.0
		650	30		
		780	25		
88	250-200-315B	400	28	55	7.0
		580	25		
		700	20		
89	250-200-400	525	60	160	7.0
		750	55		
		900	49		
90	250-200-400A	455	55	132	7.0
		650	50		
		780	45		
91	250-200-400B	420	50	110	7.0
		600	45		
		720	40		

Performance data sheet

50Hz4-pole motor

92	300-250-250	560	24.5	75	8.5
		800	20		
		960	15.5		
93	300-250-250A	500	21.5	55	8.5
		720	17		
		860	14		
94	300-250-315	700	36.5	110	8.2
		1000	32		
		1200	27.5		
95	300-250-315A	630	32.5	90	8.5
		900	28		
		1080	23.5		
96	300-250-315B	560	29.5	75	8.5
		800	25		
		960	20.5		
97	300-250-400	700	61	200	8.2
		1000	55		
		1200	50.5		
98	300-250-400A	630	56.6	160	8.5
		900	50		
		1080	44.2		
99	300-250-400B	560	50.5	132	8.5
		800	45		
		960	38.5		
100	300-250-400C	560	45.5	110	8.5
		750	40		
		960	33.5		

Performance data sheet
50Hz2-pole motor

S/N	Model	Flow rate (m ³ /h)	Head (m)	Motor power (kw)	Rated speed (r/min)	NPSH (m)
1	40-32-125	4.4	21.5	1.1	2900	2.0
		6.3	20			
		8.2	18			
2	40-32-125A	3.9	17.5	0.75	2900	2.0
		5.5	16			
		7.2	14			
3	40-32-160	4.4	37.5	3	2900	2.0
		6.3	36			
		8.2	34			
4	40-32-160A	4.1	33.5	2.2	2900	2.0
		5.9	32			
		7.6	30			
5	40-32-160B	3.9	31.5	1.5	2900	2.0
		5.5	28			
		7.2	26			
6	50-32-125	8.8	21.5	1.5	2900	2.2
		12.5	20			
		16.3	18			
7	50-32-125A	8.1	17.5	1.1	2900	2.2
		11.5	16			
		15	14			
8	50-32-160	8.8	37.5	4	2900	2.2
		12.5	36			
		16.3	34			
9	50-32-160A	8.1	33.5	3	2900	2.2
		11.5	32			
		15	30			
10	50-32-160B	7.4	29.5	2.2	2900	2.2
		10.5	28			
		13.7	26			
11	50-32-200	17.5	61.2	7.5	2900	2.2
		25	56			
		32.5	49			
12	50-32-200A	16.5	55.1	7.5	2900	2.4
		23.5	50			
		30.6	40.5			
13	50-32-200B	15.1	48.5	5.5	2900	2.4
		21.5	44			
		28	35.2			

Performance data sheet
50Hz2-pole motor

S/N	Model	Flow rate (m ³ /h)	Head (m)	Motor power (kw)	Rated speed (r/min)	NPSH (m)
14	65-50-125	17.5	21.5	3	2900	3.0
		25	20			
		32.5	18			
15	65-50-125A	16.5	17.5	2.2	2900	3.0
		23.5	16			
		30.6	14			
16	65-50-160	35	39	11	2900	3.0
		50	36			
		65	32			
17	65-50-160A	31.5	35	7.5	2900	3.2
		45	32			
		58.5	26.5			
18	65-50-160B	29.8	29	5.5	2900	3.2
		42.5	26			
		55.3	20.5			
19	65-40-200	35	62	15	2900	3.0
		50	56			
		65	49			
20	65-40-200A	31.5	51.5	11	2900	3.2
		45	47			
		58.5	37.6			
21	65-40-200B	29.8	41.8	7.5	2900	3.2
		42.5	38			
		55.3	30.6			
22	65-40-250	35	95.5	22	2900	3.0
		50	88			
		65	80			
23	65-40-250A	31.5	80.3	18.5	2900	3.2
		45	75			
		58.5	58.4			
24	65-40-250B	29.8	67.8	15	2900	3.2
		42.5	62			
		55.3	50.4			
25	65-40-315	35	151	45	2900	3.0
		50	140			
		65	128			
26	65-40-315A	31.5	138	37	2900	3.2
		45	130			
		58.5	119			

Performance data sheet
50Hz2-pole motor

S/N	Model	Flow rate (m ³ /h)	Head (m)	Motor power (kw)	Rated speed (r/min)	NPSH (m)
27	65-40-315B	29.8	127	30	2900	3.2
		42.5	120			
		55.3	108			
28	80-65-160	70	39.5	15	2900	4.2
		100	36			
		130	31			
29	80-65-160A	66.5	35.5	15	2900	4.5
		95	32			
		123	26			
30	80-65-160B	63	31.5	11	2900	4.5
		90	28			
		117	22			
31	80-50-200	70	61	30	2900	4.2
		100	56			
		130	50.5			
32	80-50-200A	66.5	55	22	2900	4.5
		95	50			
		123	44.5			
33	80-50-200B	63	50.5	18.5	2900	4.5
		90	45			
		117	39.5			
34	80-50-250	70	95	45	2900	4.2
		100	88			
		130	81			
35	80-50-250A	66.5	87	37	2900	4.5
		95	80			
		123	72.5			
36	80-50-250B	63	76.5	30	2900	4.5
		90	70			
		117	62			
37	80-50-315	70	151	75	2900	4.2
		100	140			
		130	128			
38	80-50-315A	66.5	131	55	2900	4.5
		95	120			
		123	105			
39	80-50-315B	63	109.5	45	2900	4.5
		90	100			
		117	84.5			

Performance data sheet
50Hz2-pole motor

S/N	Model	Flow rate (m ³ /h)	Head (m)	Motor power (kw)	Rated speed (r/min)	NPSH (m)
40	100-80-160	112	40.5	22	2900	4.5
		160	36			
		192	31			
41	100-80-160A	105	34.5	18.5	2900	4.8
		150	30			
		180	25			
42	100-80-160B	98	29.5	15	2900	4.8
		140	25			
		168	20.5			
43	100-65-200	112	61	37	2900	4.8
		160	56			
		192	50.5			
44	100-65-200A	105	52.8	30	2900	5.0
		150	48			
		180	39.5			
45	100-65-200B	98	44.5	22	2900	5.0
		140	40			
		168	32.5			
46	100-65-250	112	95	75	2900	4.8
		160	88			
		192	81			
47	100-65-250A	105	87	55	2900	5.0
		150	80			
		180	72			
48	100-65-250B	98	82	45	2900	5.0
		140	75			
		168	65			
49	100-65-315	112	151	110	2900	4.8
		160	140			
		192	128			
50	100-65-315A	105	131	90	2900	5.0
		150	130			
		180	118			
51	100-65-315B	98	130	75	2900	5.0
		140	120			
		168	108			
52	125-100-200	210	63	75	2900	7.0
		300	56			
		360	49			

Performance data sheet

50Hz2-pole motor

S/N	Model	Flow rate (m ³ /h)	Head (m)	Motor power (kw)	Rated speed (r/min)	NPSH (m)
53	125-100-200A	182	54.9	55	2900	7.0
		260	50			
		312	41.2			
53	125-100-200A	182	54.9	55	2900	7.0
		260	50			
		312	41.2			
54	125-100-200B	154	49.5	45	2900	7.0
		220	45			
		264	37.5			
55	125-100-250	210	88	90	2900	7.0
		300	80			
		360	71			
56	125-100-250A	192	82.5	75	2900	7.0
		275	75			
		358	65.8			
57	125-100-250B	175	76.5	55	2900	7.0
		250	70			
		325	62			
58	125-100-250S	154	88	75	2900	7.0
		220	80			
		264	71			
59	125-100-250SA	140	78	55	2900	7.0
		200	75			
		240	61			
60	125-100-315	210	142.5	160	2900	7.0
		300	130			
		360	108.5			
61	125-100-315A	192	126.7	132	2900	7.0
		275	115			
		358	92.7			
62	125-100-315B	175	115.6	110	2900	7.0
		250	105			
		325	86.2			
63	125-100-315S	154	143	132	2900	7.0
		220	130			
		264	108			
64	125-100-315SA	140	126	110	2900	7.0
		200	115			

Performance curves

50Hz 4-pole motor

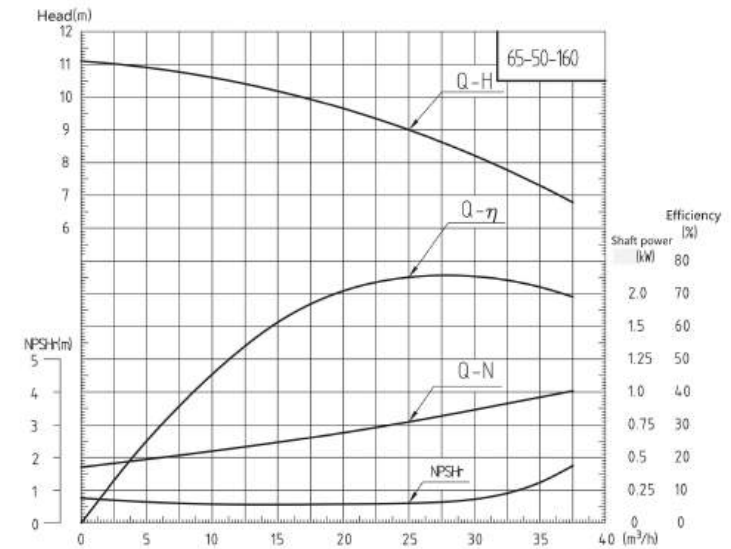
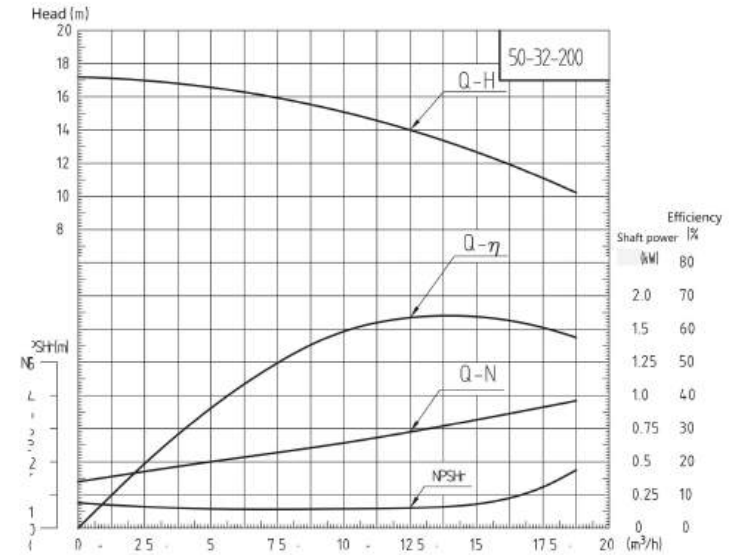

50Hz 4-pole motor

50Hz 4-pole motor

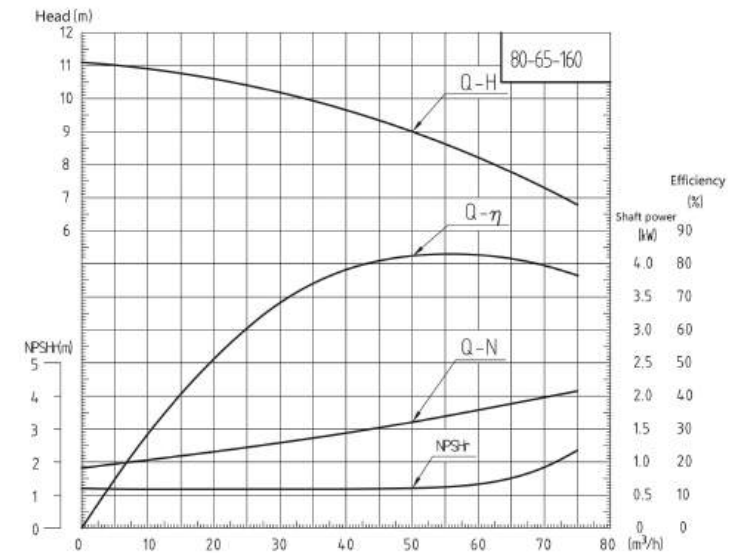
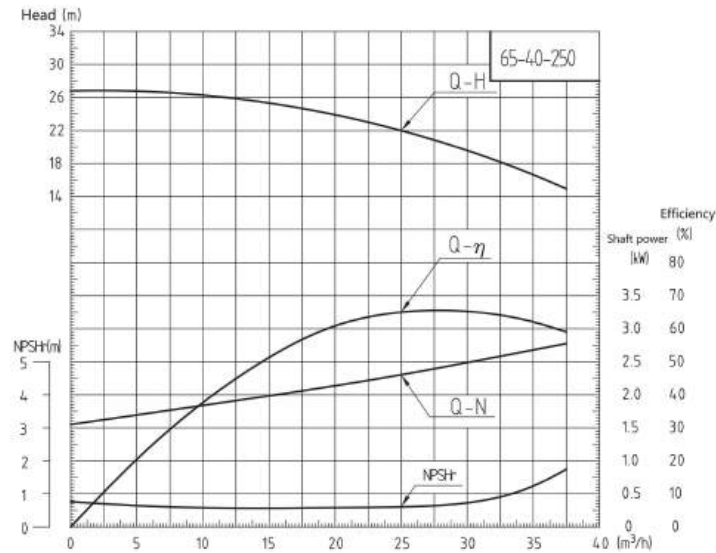
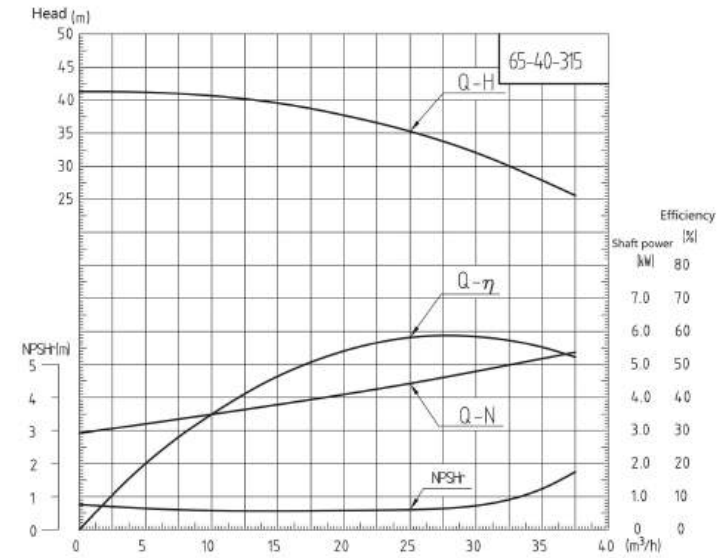
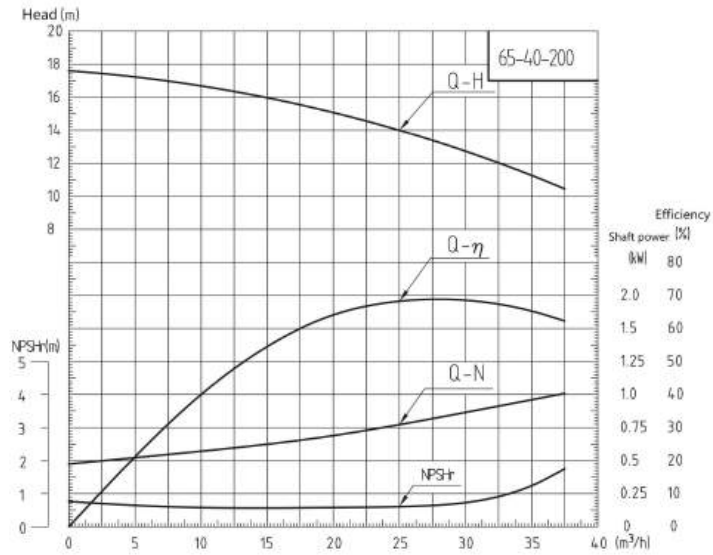

50Hz 4-pole motor

50Hz 4-pole motor

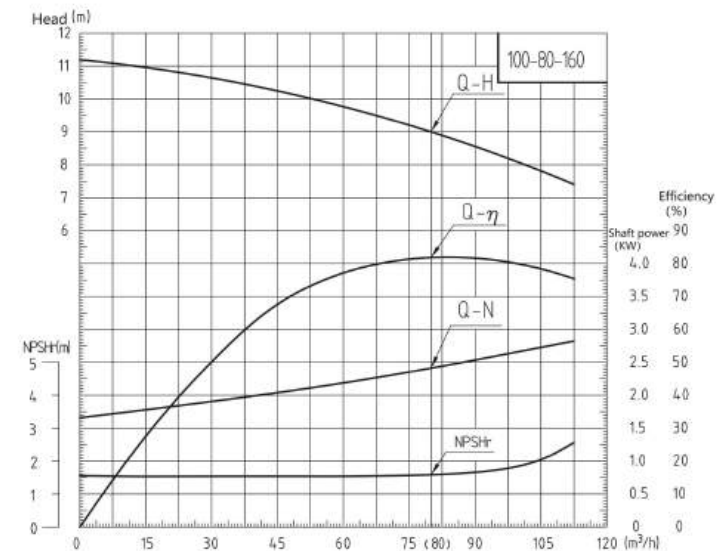
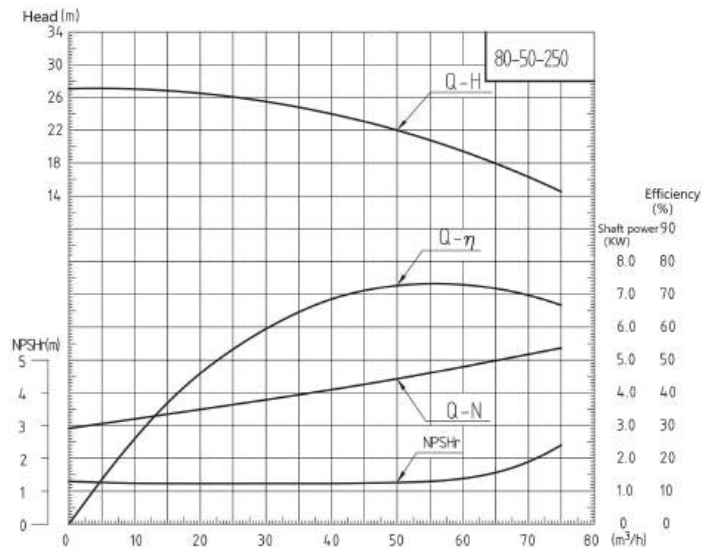
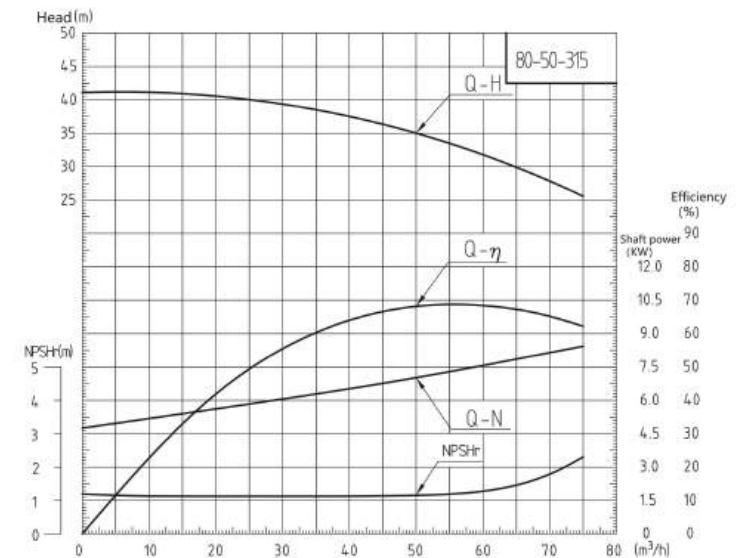
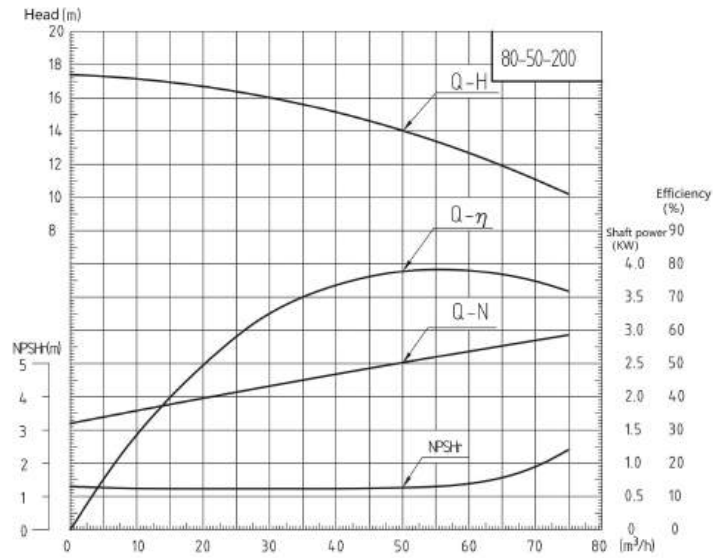

50Hz 4-pole motor

50Hz 4-pole motor

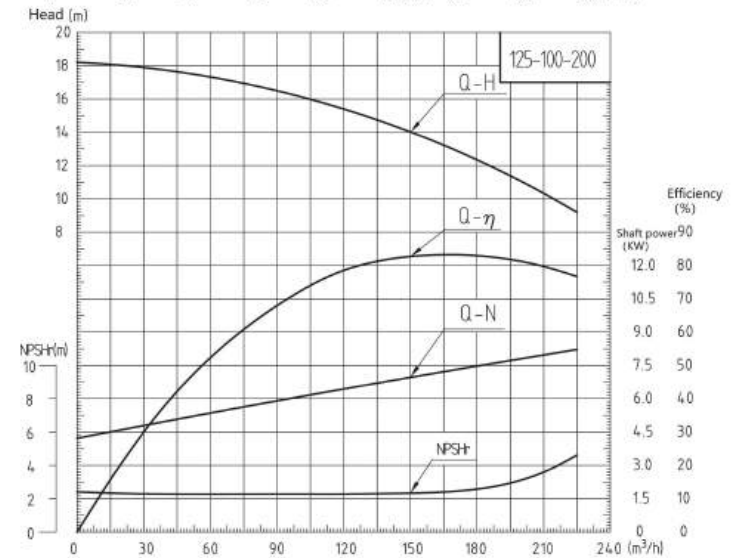
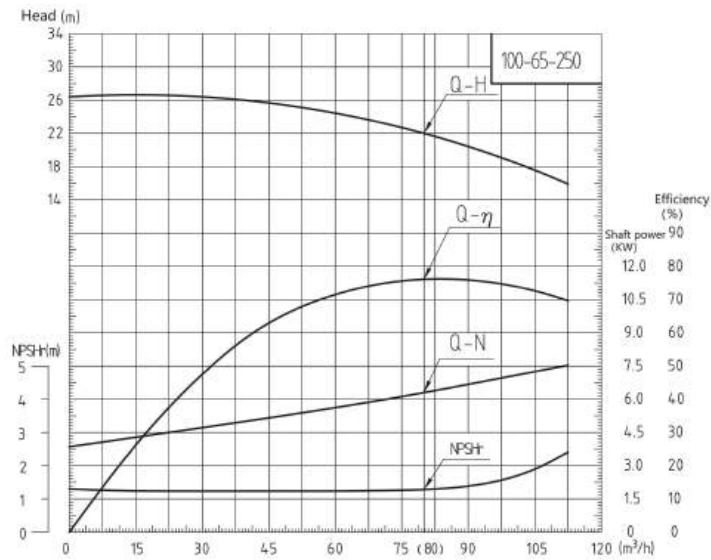
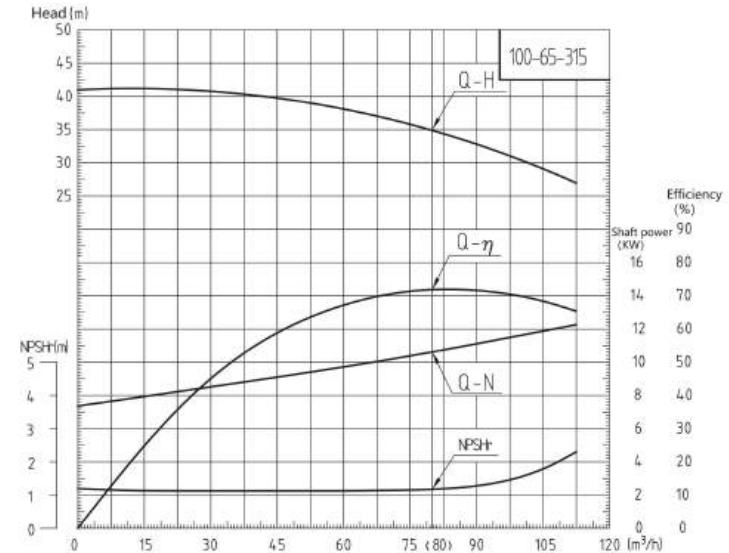
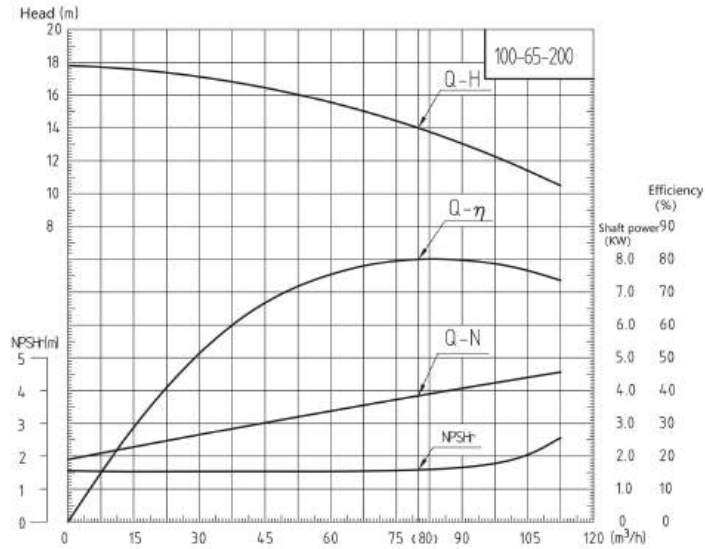

50Hz 4-pole motor

50Hz 4-pole motor

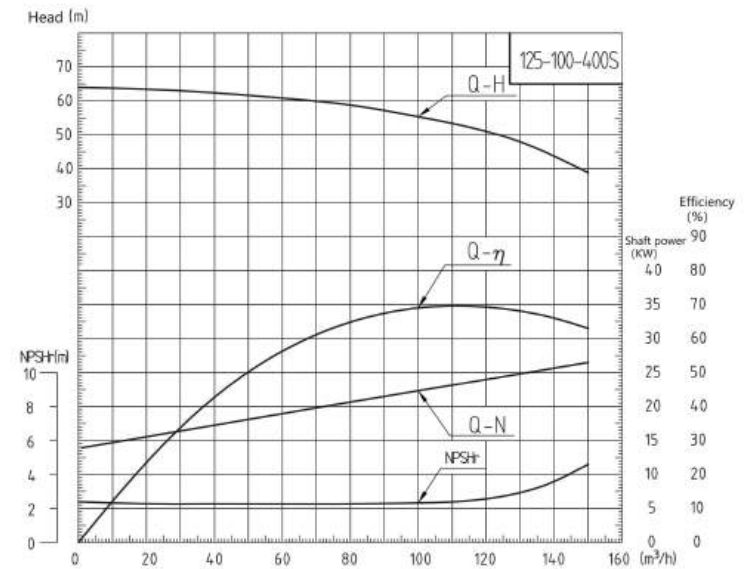
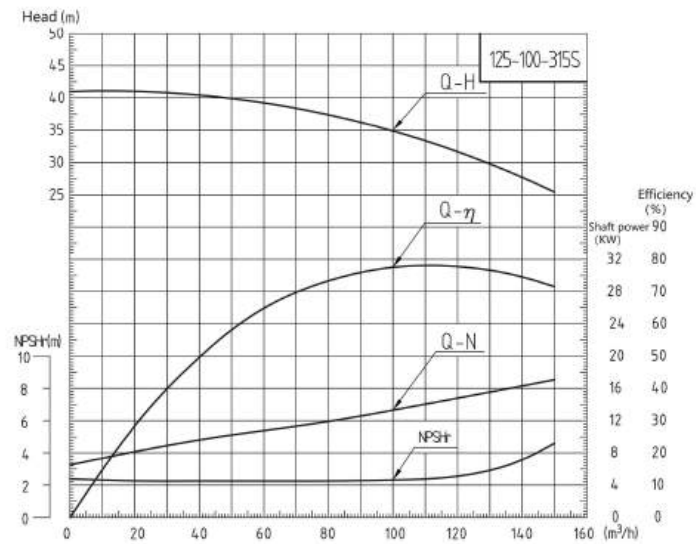
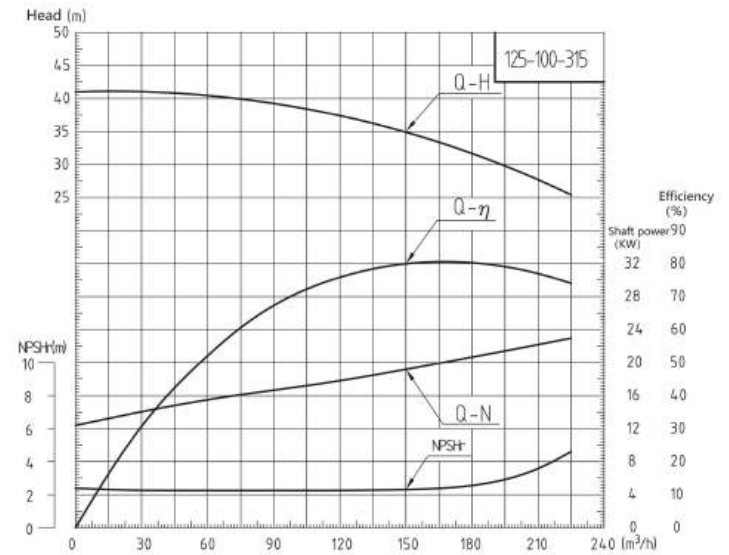
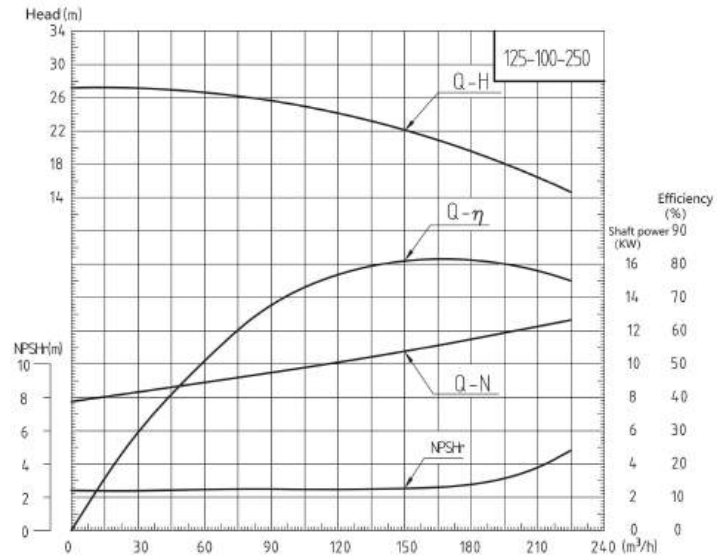

50Hz 4-pole motor

50Hz 4-pole motor

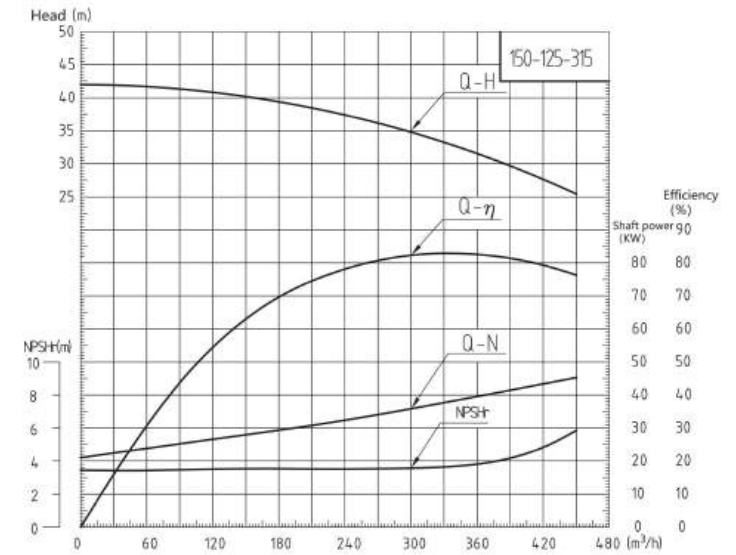
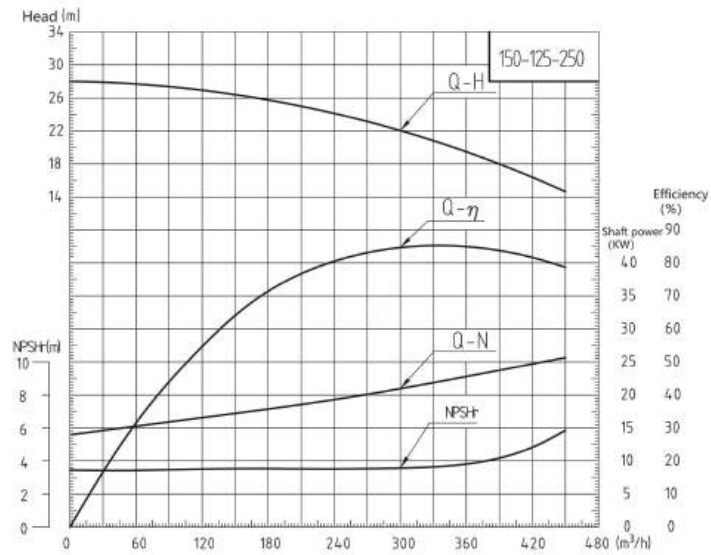
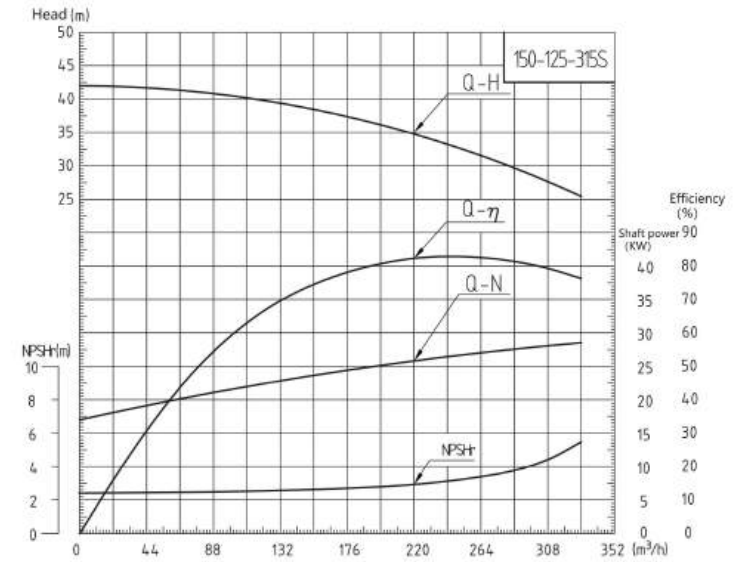
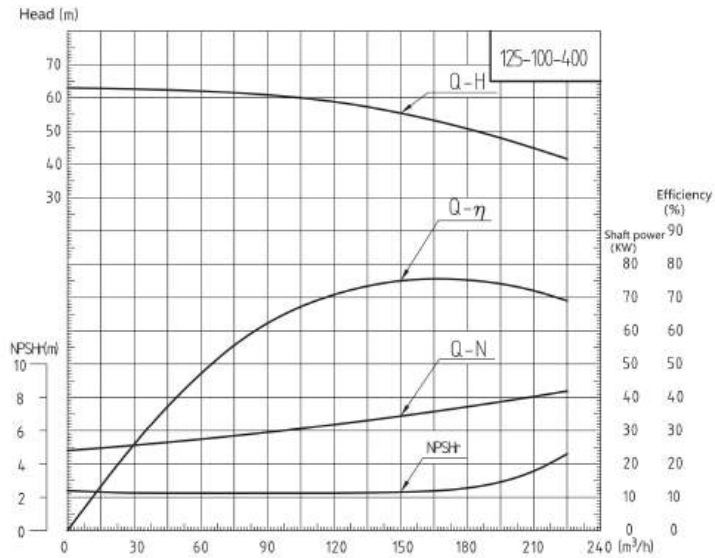

50Hz 4-pole motor

50Hz 4-pole motor

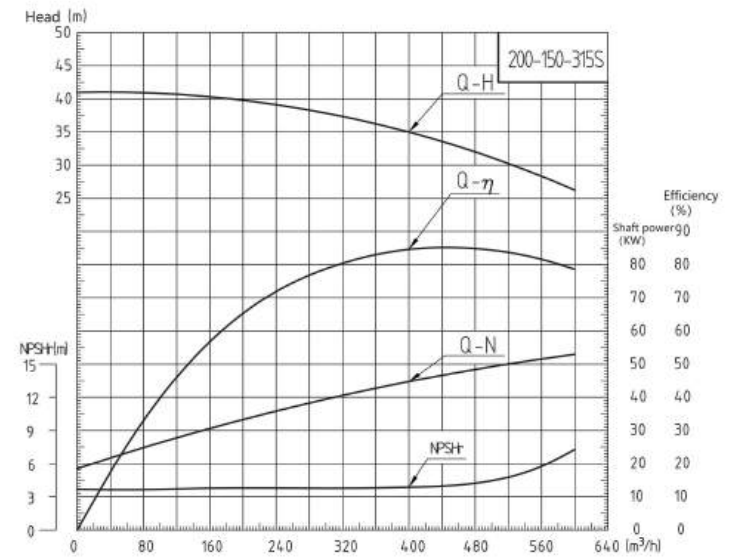
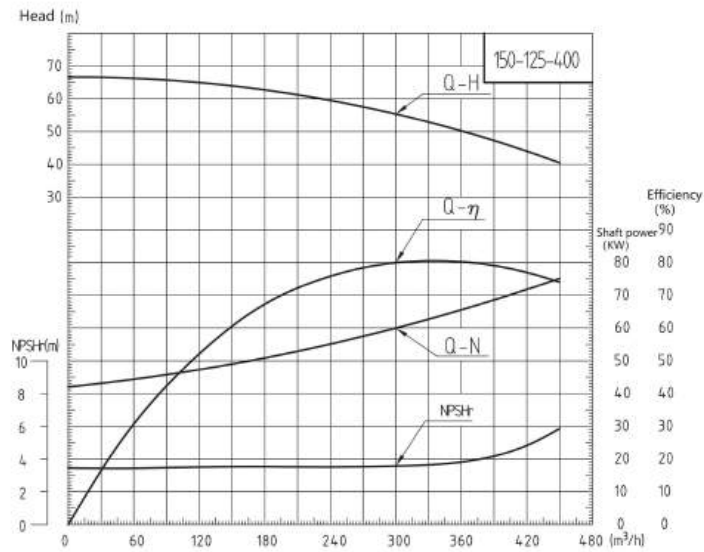
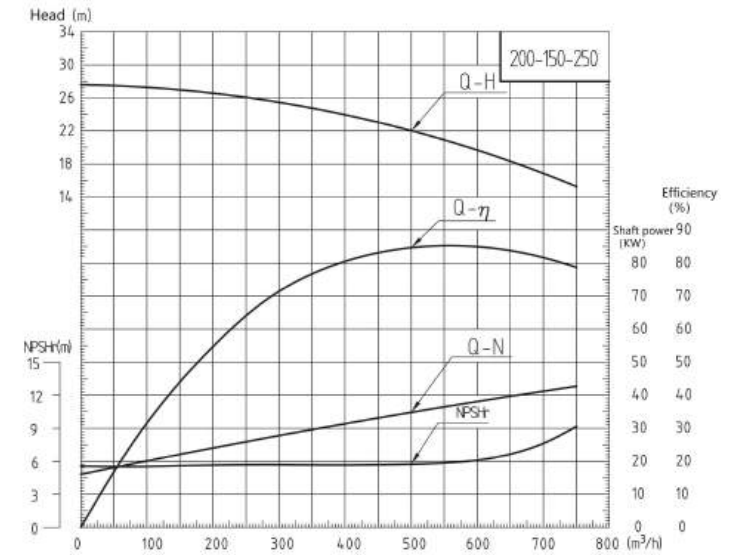
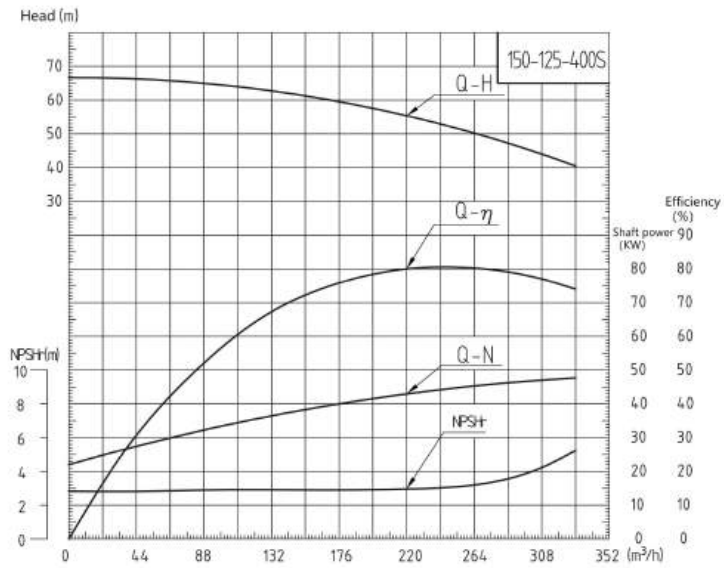

50Hz 4-pole motor

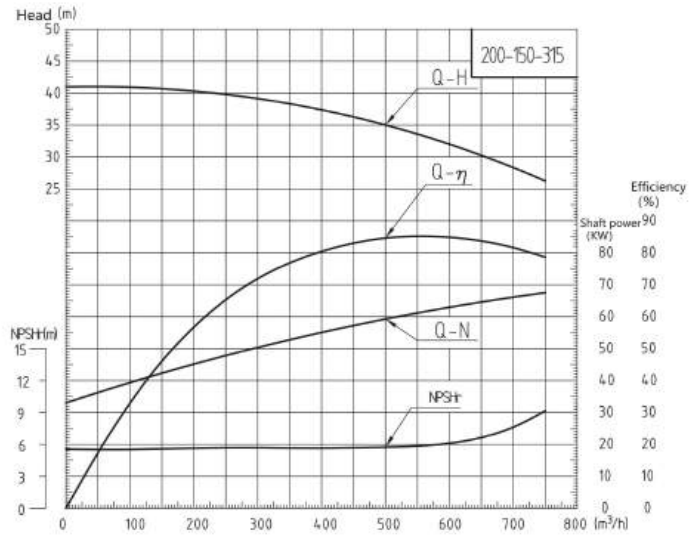

50Hz 4-pole motor

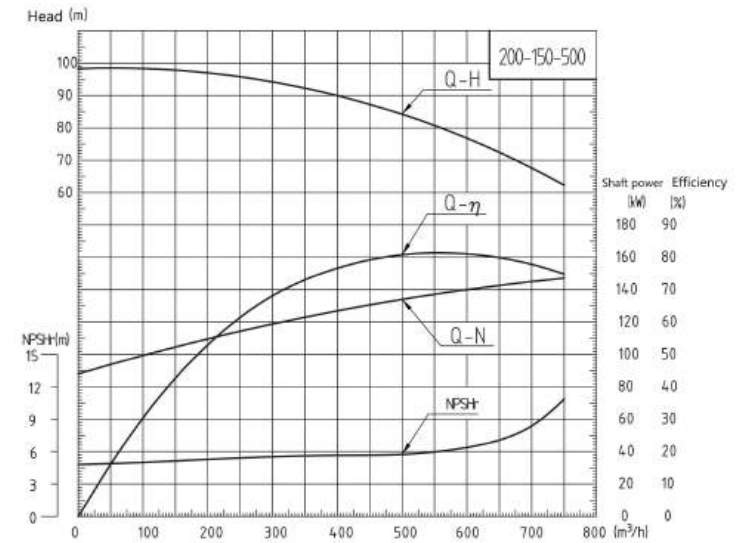
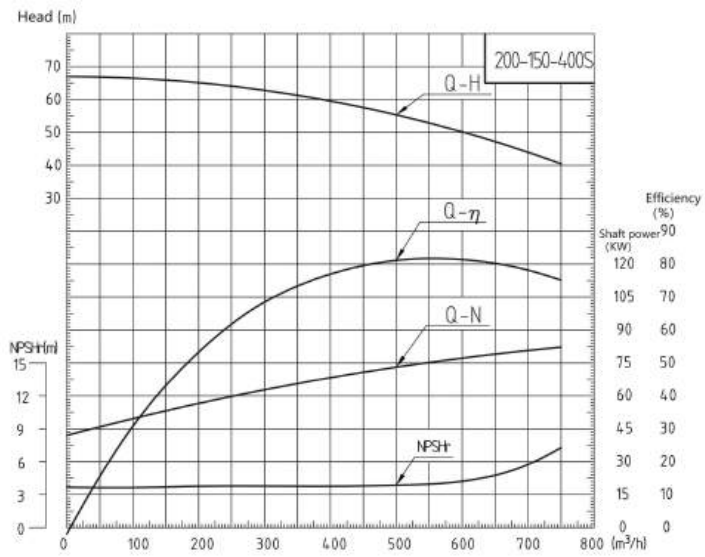
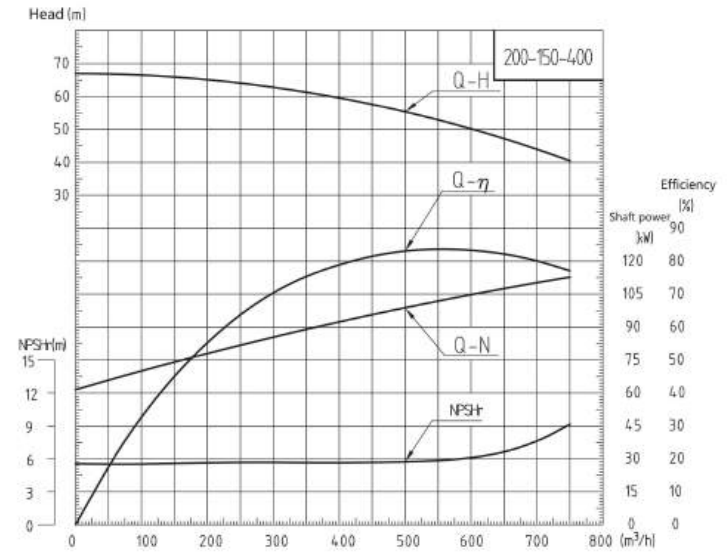

50Hz 4-pole motor

50Hz 4-pole motor

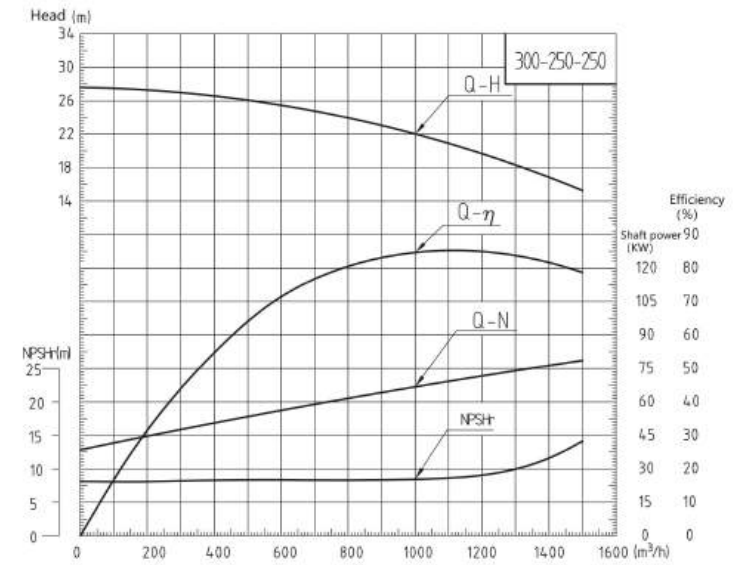
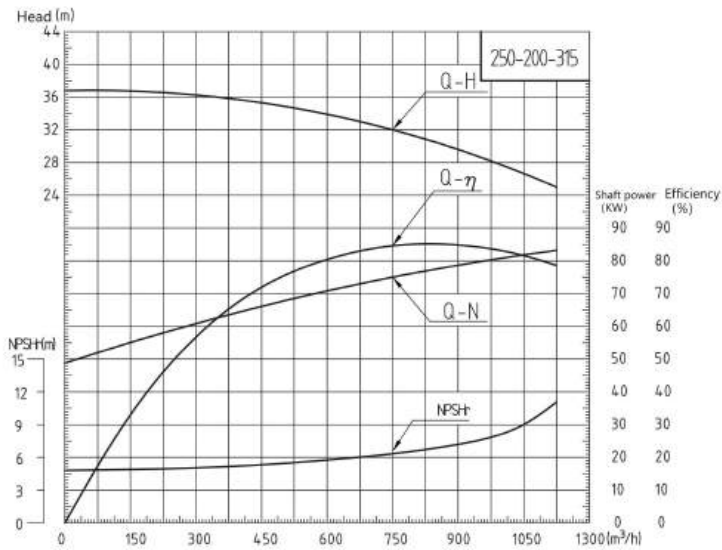
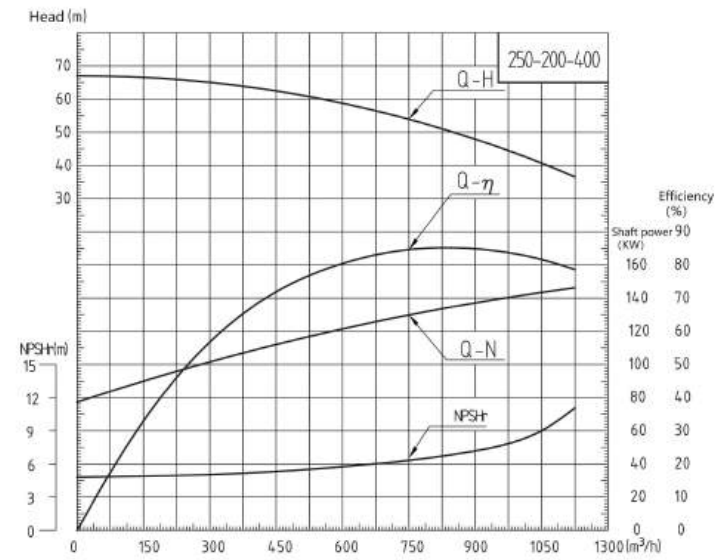
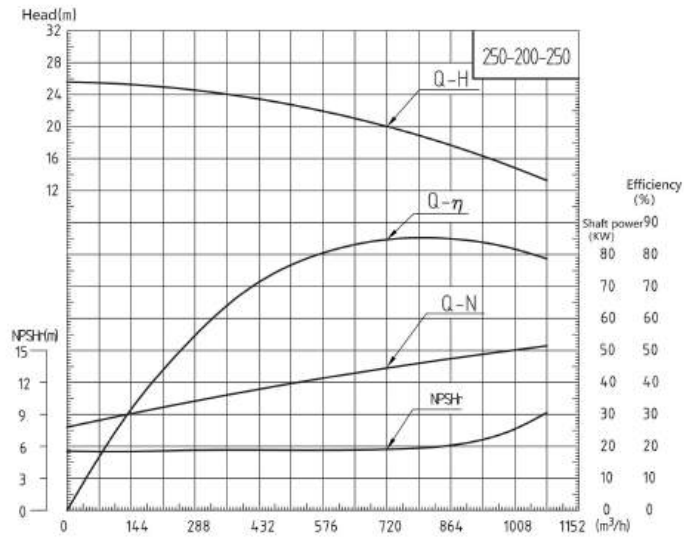

50Hz 4-pole motor

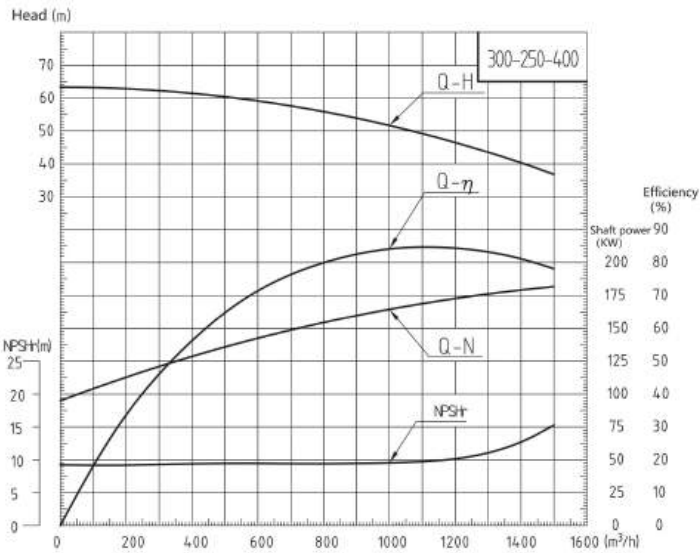
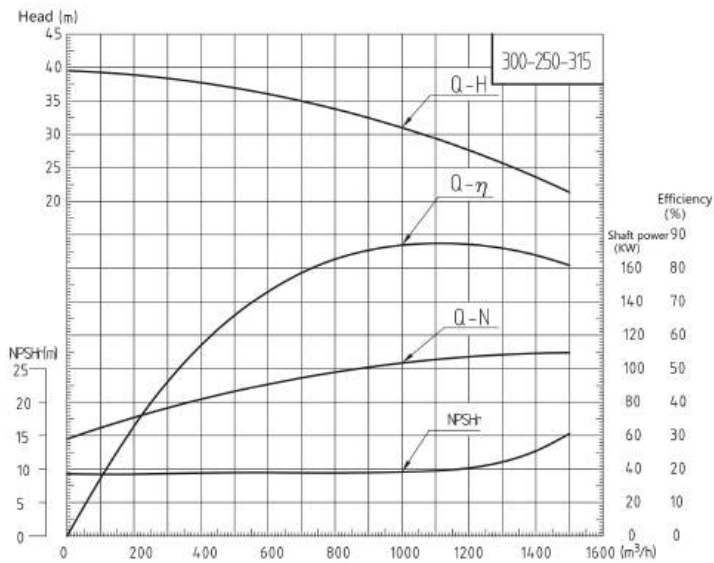

50Hz 2-pole motor

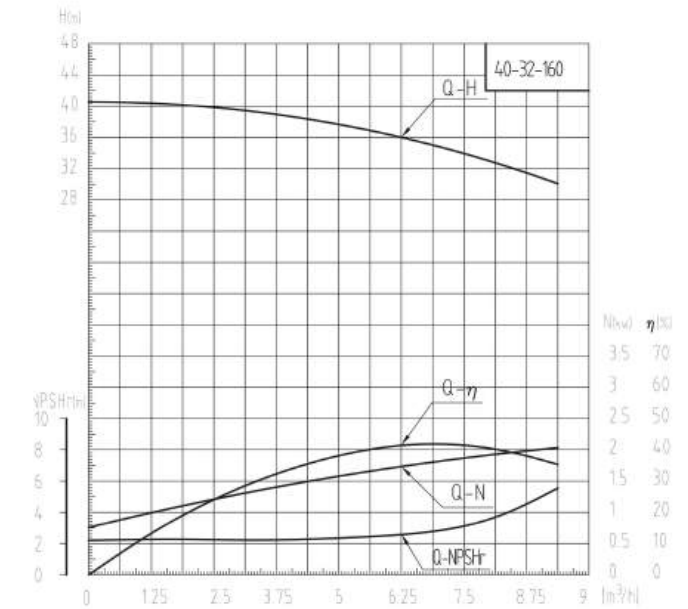
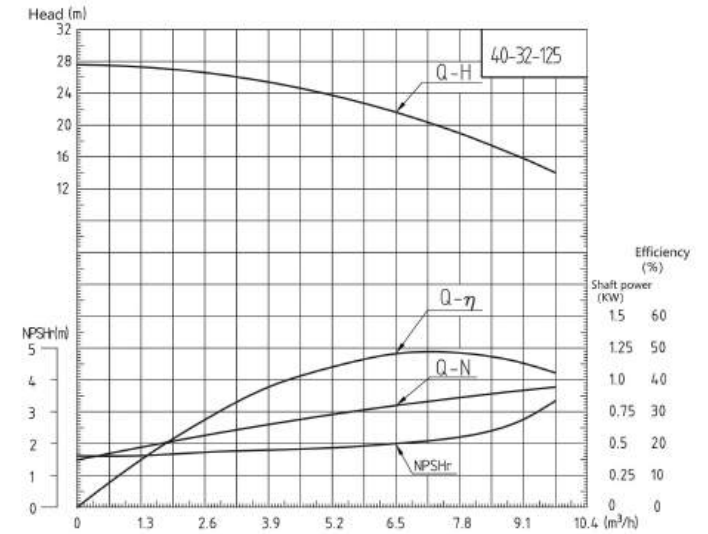

50Hz 2-pole motor

50Hz 2-pole motor

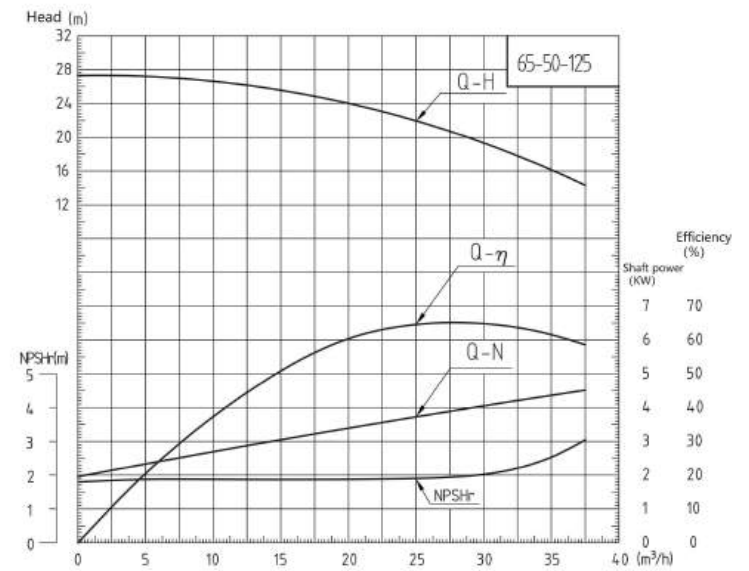
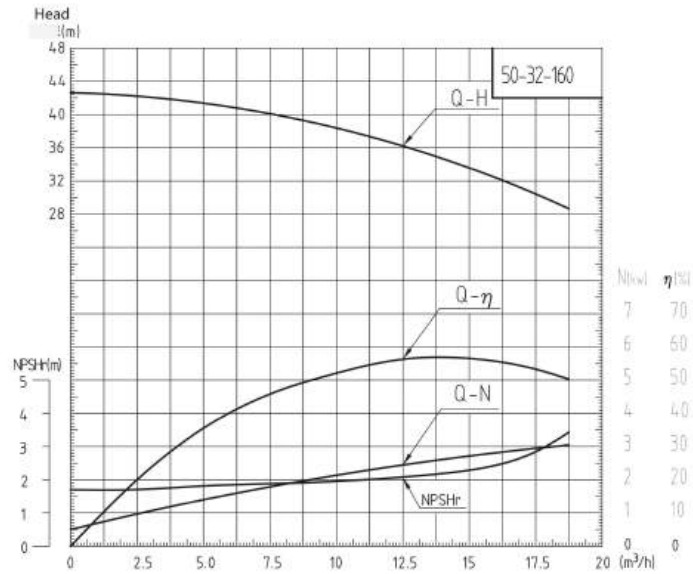
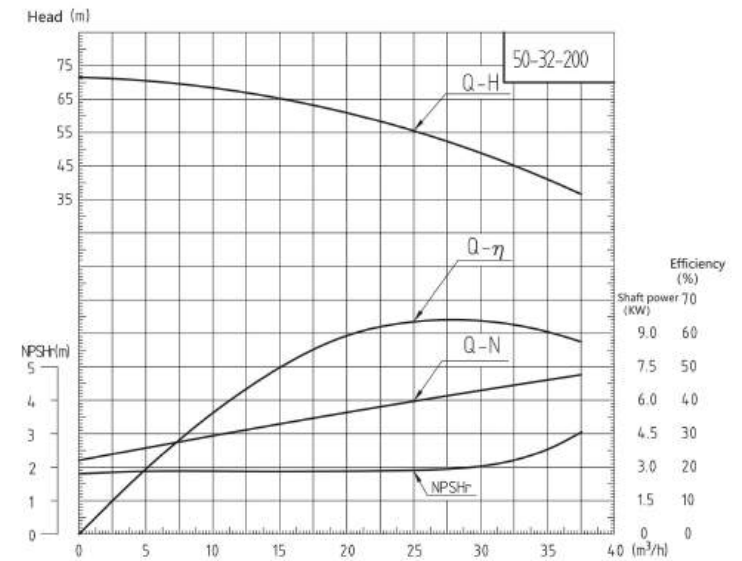
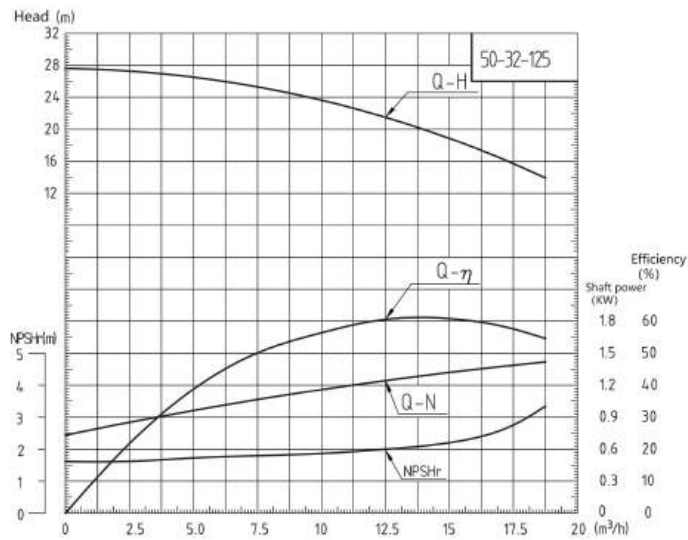

50Hz 2-pole motor

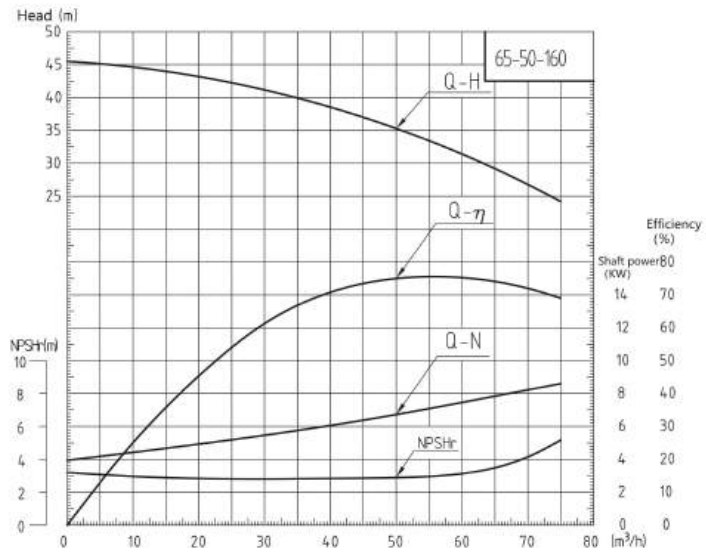

50Hz 2-pole motor

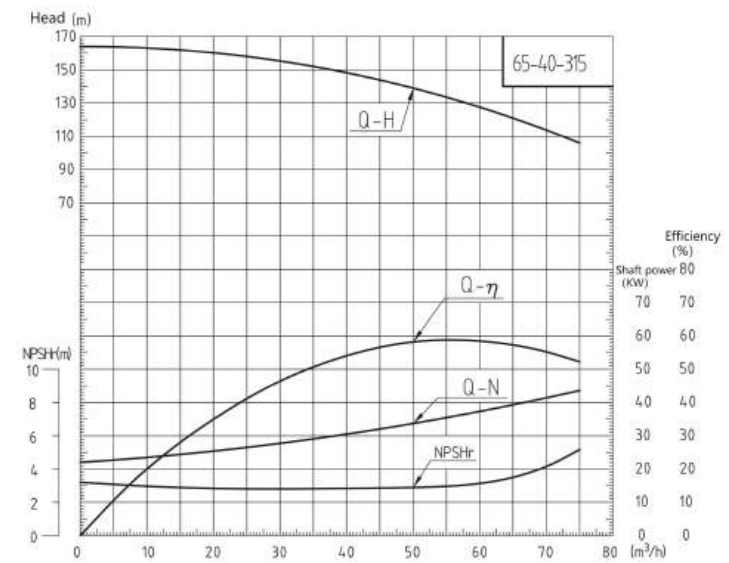
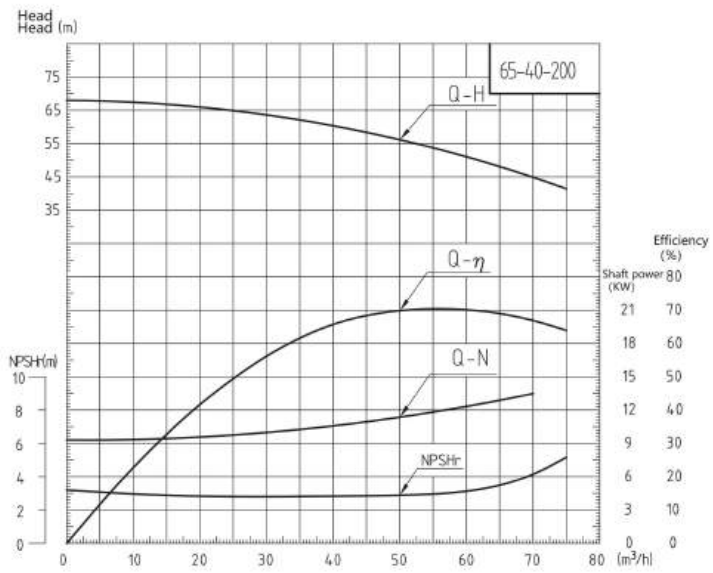
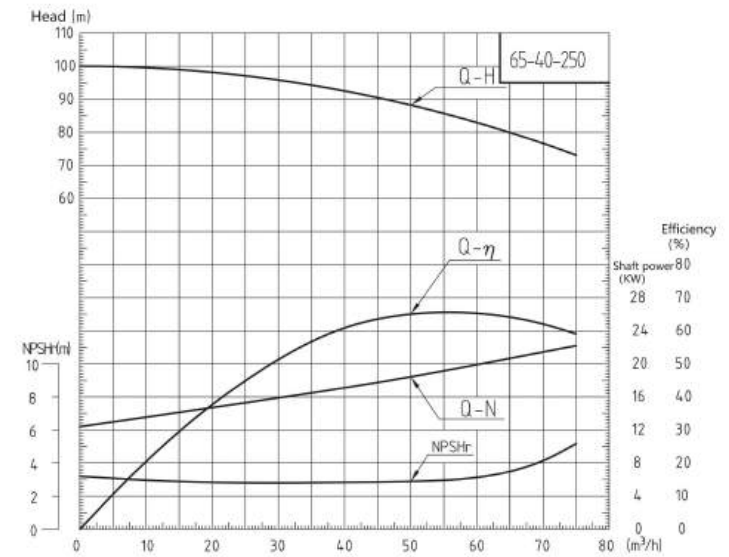

50Hz 2-pole motor

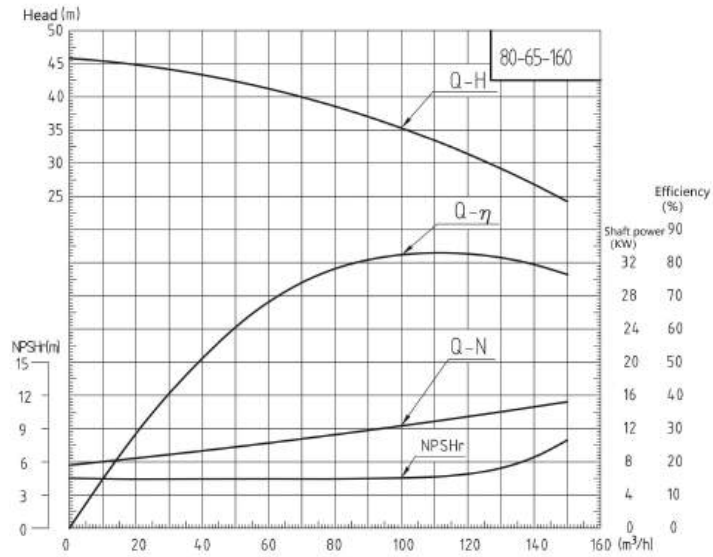

50Hz 2-pole motor

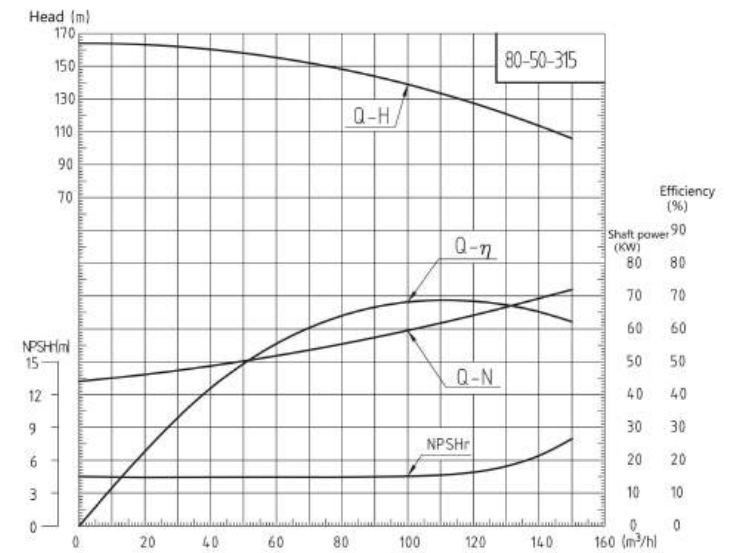
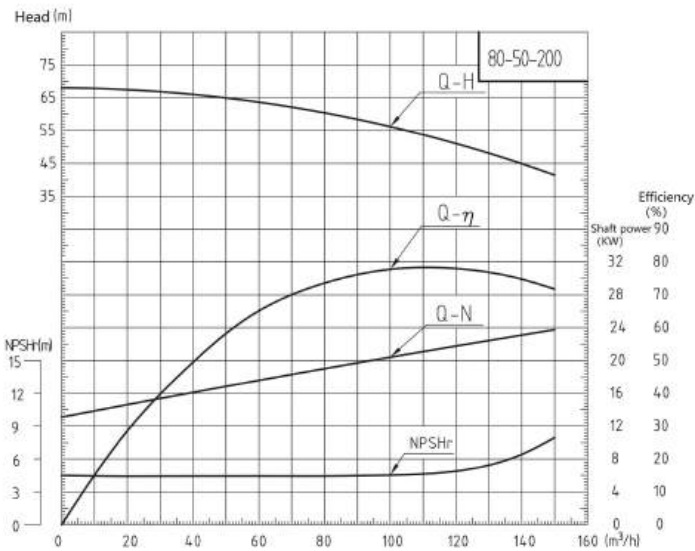
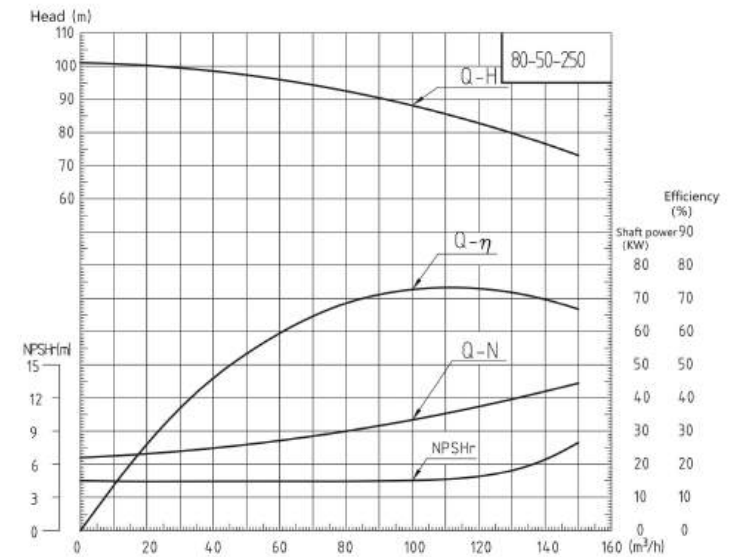

50Hz 2-pole motor

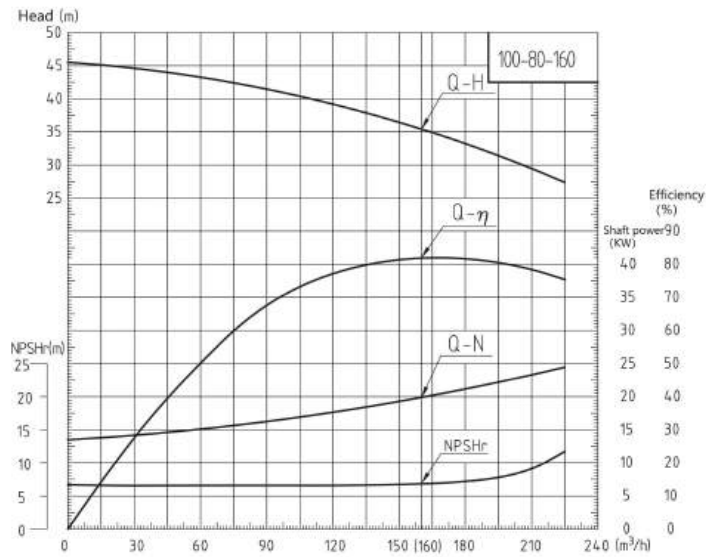

50Hz 2-pole motor

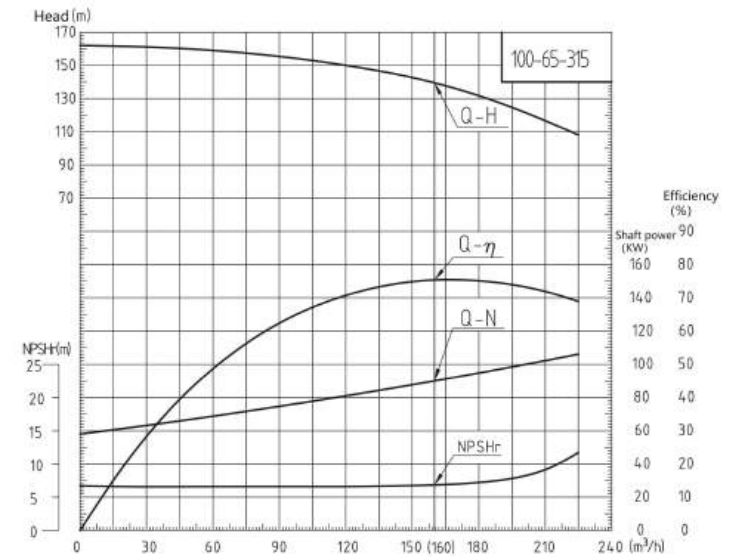
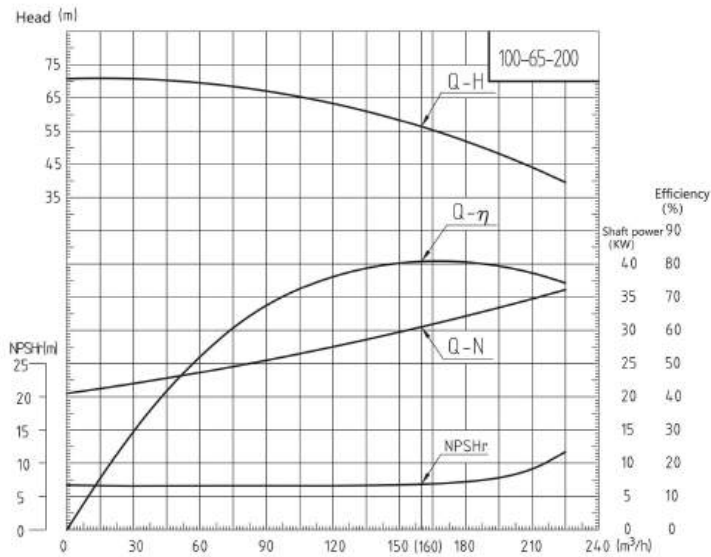
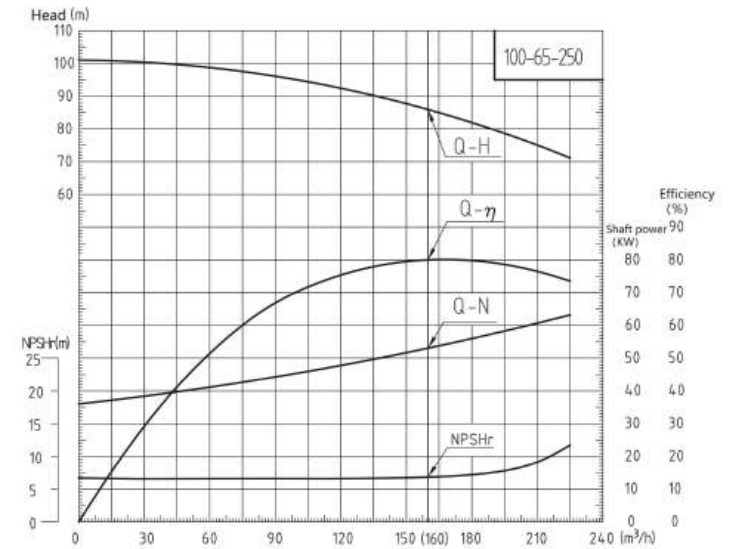

50Hz 2-pole motor

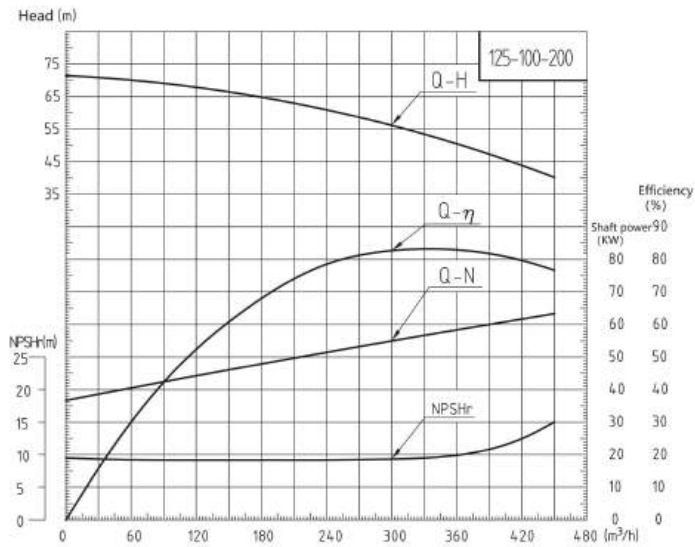

50Hz 2-pole motor

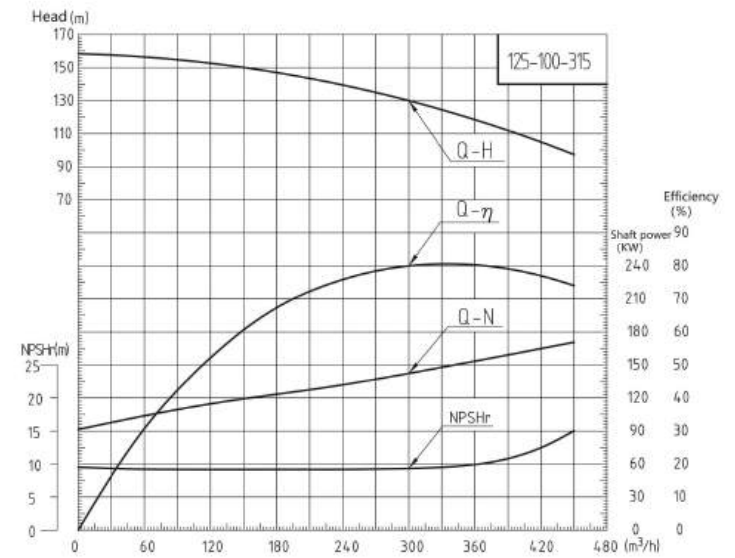
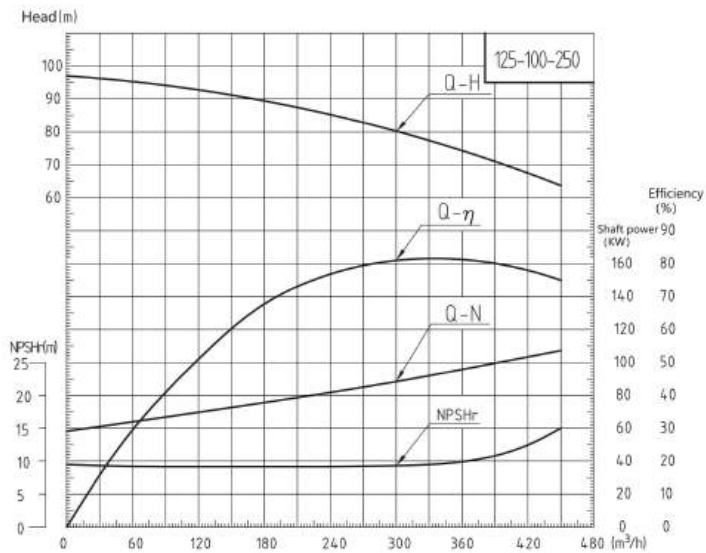
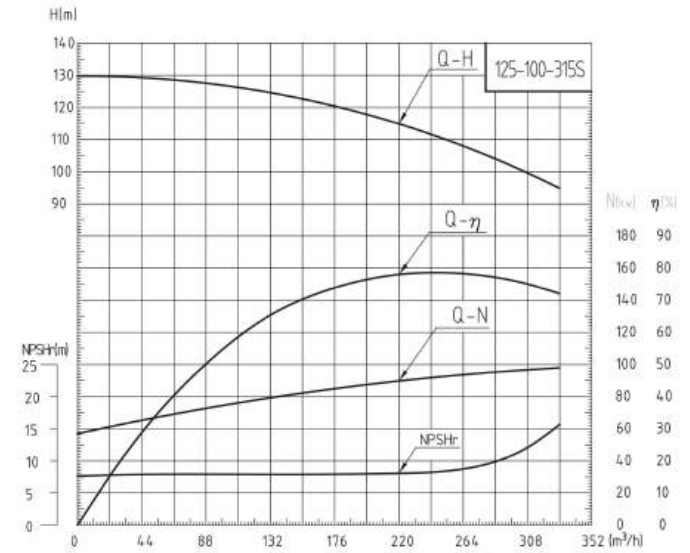

dimensions

Horizontal Close-Coupled End Suction Pump

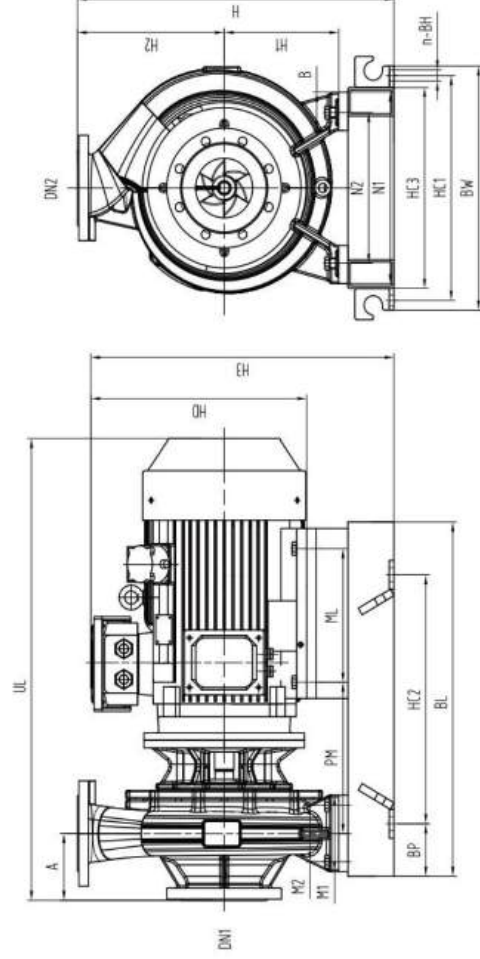

Model with 4-pole motor

Model	Motor		Pump Overall Dimensions (mm)													Pump set Overall Dimensions (mm)									
	kW	DN1	DN2	A	B	N1	N2	M1	M2	H1	H2	PM	ML	ML	HD	UL	BP	HC1	HC2	HC3	BW	BL	n-BH	H	H3
50-50-300	0.75	50	32	80	50	240	190	100	70	160	195	216	100	250	485	50	305	300	260	340	400	410	4-15	435	410
	1.1	50	32									216	100	260	520	55	305	300	260	340	410	410	4-15	435	410

Model	Motor		Pump Overall Dimensions (mm)													Pump set Overall Dimensions (mm)												
	kW	DN1	DN2	A	B	N1	N2	M1	M2	H1	H2	PM	ML	ML	HD	UL	BP	HC1	HC2	HC3	BW	BL	n-BH	H	H3			
65-50-160	0.75	65	50	80	50	240	190	100	70	132	170	216	100	250	485	50	305	300	260	340	400	400	4-15	382	382			
	1.1	65	50									216	100	260	520	55	305	300	260	340	410	410	4-15	382	382			
65-40-200	1.1	65	40									216	100	260	540	55	325	300	280	360	410	410	4-15	440	410			
	1.5	65	40	100	50	265	212	100	70	160	200	216	125	260	565	70	325	300	280	360	440	410	4-15	440	410			
65-40-250	2.2	65	40									223	140	280	610	80	325	300	280	360	460	460	4-15	440	420			
	3	65	40	100	50	320	250	125	95	180	225	247	140	280	610	80	375	300	330	390	460	460	4-15	485	440			
65-40-315	4	65	40									257	140	310	645	95	405	300	360	440	490	490	4-15	560	498			
	5.5	65	40	125	65	345	280	125	95	220	260	257	140	330	685	85	405	350	360	440	520	520	4-18	560	498			
80-65-160	1.1	80	65									216	100	260	540	55	325	300	280	360	410	410	4-15	420	410			
	1.5	80	65	100	50	265	212	100	70	160	180	216	125	260	566	70	325	300	280	360	440	410	4-15	420	410			
80-50-200	2.2	80	65									223	140	280	610	80	325	300	280	360	440	440	4-15	420	420			
	3	80	65	100	50	265	212	100	70	140	205	223	140	280	610	80	325	300	280	360	460	460	4-15	445	420			
80-50-250	4	80	50									245	140	310	660	70	385	350	340	420	490	490	4-15	490	458			
	5.5	80	50	125	65	320	250	125	95	180	230	269	140	330	675	80	385	350	340	420	510	510	4-18	490	458			
80-50-315	5.5	80	50									269	140	330	675	80	405	350	360	440	510	510	4-18	585	503			
	7.5	80	50	125	65	345	280	125	95	225	280	269	178	310	715	75	405	400	360	440	550	550	4-18	585	503			
100-80-160	11	80	50									293	210	420	788	80	405	450	360	440	610	610	4-18	585	565			
	2.2	100	80	100	65	280	212	125	95	160	215	223	140	280	610	85	345	300	300	380	470	470	4-15	455	420			
100-80-200	3	100	80									223	140	280	610	85	345	300	300	380	470	470	4-15	455	420			
	3	100	65									238	140	280	625	70	385	350	340	420	490	490	4-15	485	440			
100-65-200	4	100	65	100	65	320	250	125	95	180	225	245	140	310	635	70	385	350	340	420	490	490	4-15	485	458			
	5.5	100	65									269	140	330	650	80	385	350	340	420	510	510	4-18	485	458			

Model	Motor		Inlet flange		Pump Overall Dimensions (mm)																Pump set Overall Dimensions (mm)							
	DN1	DN2	A	B	N1	N2	M1	M2	H1	H2	PM	ML	HD	UL	BP	HCL	HC2	HC3	BW	BL	n-BH	H	H3					
100-65-250	5.5	100	65	100	65	360	280	160	120	200	250	269	140	330	675	90	425	350	380	460	530	4-18	530	478				
	7.5	100	65									269	178	330	718	90	425	400	380	460	580	4-18	530	478				
100-65-315	7.5	100	65									283	178	330	725	90	465	400	420	500	580	4-18	585	503				
	11	100	65	125	80	400	315	160	120	225	280	303	210	420	825	95	465	450	420	500	640	4-18	585	565				
125-100-65	15	100	65									303	254	420	880	95	465	500	420	500	690	4-18	585	565				
	5.5	125	100									269	140	330	690	90	425	350	380	460	530	4-18	560	478				
125-100-200	7.5	125	100	125	80	360	280	160	120	200	280	269	178	330	715	85	425	400	380	460	570	4-18	560	478				
	11	125	100									293	210	420	815	100	425	430	380	460	630	4-18	560	540				
125-100-250	11	125	100	140	80	400	315	160	120	225	290	302	210	420	845	95	465	450	420	500	640	4-18	595	565				
	15	125	100									302	254	420	895	95	465	500	420	500	690	4-18	595	565				
125-100-315	15	125	100									303	254	420	895	100	470	520	420	510	720	4-18	690	610				
	18.5	125	100	140	80	400	315	160	120	250	320	316	241	450	905	100	470	540	420	510	740	4-18	690	640				
125-100-400	22	125	100									316	279	450	965	100	470	540	420	510	740	4-18	690	640				
	22	125	100									311	279	450	960	105	570	550	520	610	760	4-18	760	670				
150-125-250	30	125	100	140	100	500	400	200	149	280	360	328	305	510	995	100	570	600	520	610	800	4-18	760	710				
	37	125	100									354	286	550	1020	105	570	600	520	610	830	4-18	760	725				
150-125-315	38.5	150	125									316	241	450	925	100	470	500	420	510	700	4-18	725	640				
	22	150	125	140	80	400	315	160	149	250	355	316	279	450	965	110	470	520	420	510	740	4-18	725	640				
150-125-400	30	150	125									333	305	510	998	115	470	550	420	510	780	4-18	755	680				
	30	150	125									348	305	510	1015	105	570	600	520	610	810	4-18	755	710				
150-125-315	37	150	125	140	100	500	400	200	149	280	355	369	286	550	1060	110	570	600	520	610	820	4-18	755	725				
	45	150	125									369	311	550	1065	100	570	650	520	610	850	4-18	755	725				
150-125-400	45	150	125									369	311	550	1075	105	570	650	520	620	860	4-18	835	760				
	55	150	125	140	100	500	400	200	149	315	400	393	349	680	1140	105	570	700	520	620	910	4-18	835	865				

Model	Motor		Inlet flange		Pump Overall Dimensions (mm)																Pump set Overall Dimensions (mm)							
	DN1	DN2	A	B	N1	N2	M1	M2	H1	H2	PM	ML	HD	UL	BP	HCL	HC2	HC3	BW	BL	n-BH	H	H3					
200-150-250	75	150	125									415	368	720	1255	105	620	750	570	670	960	4-22	835	875				
	30	200	150									333	305	510	1020	100	570	600	520	620	800	6-22	775	710				
200-150-315	37	200	150	160	100	500	400	200	149	280	375	354	286	550	1035	100	570	620	520	620	820	6-22	775	725				
	45	200	150									354	311	550	1080	100	570	640	520	620	840	6-22	775	725				
200-150-400	45	200	150									369	311	550	1095	105	620	650	570	670	860	6-22	835	760				
	55	200	150	160	100	550	450	200	149	315	400	393	349	680	1160	105	620	700	570	670	910	6-22	835	865				
200-150-500	75	200	150									415	368	720	1230	105	620	750	570	670	960	6-22	835	875				
	75	200	150									415	368	720	1220	105	620	750	570	670	960	6-22	885	875				
250-200-315	90	200	150	160	100	550	450	200	149	315	450	415	419	720	1270	100	620	410	570	670	1020	6-22	885	875				
	110	200	150									446	406	870	1322	100	700	430	650	750	1060	6-22	965	1010				
250-200-400	132	200	150									446	457	870	1600	100	700	485	650	750	1170	6-27	990	1070				
	160	200	150	180	100	550	450	200	149	375	475	446	508	870	1600	100	700	485	650	750	1170	6-27	990	1070				
250-200-500	200	200	150									446	508	870	1600	100	700	485	650	750	1170	6-27	990	1070				
	45	250	200	170	100	550	450	200	149	315	400	384	311	550	1103	100	620	650	570	670	880	6-27	835	760				
250-200-315	55	250	200									389	349	680	1189	105	620	700	570	670	910	6-27	835	865				
	55	250	200									403	349	680	1175	110	620	700	570	670	920	6-27	835	865				
250-200-400	75	250	200	160	100	550	450	200	149	315	400	425	368	720	1235	110	620	770	570	670	970	6-27	835	875				
	90	250	200									425	419	720	1285	100	620	410	570	670	1020	6-27	835	875				
300-350-250	110	250	200									451	406	870	1350	100	700	435	650	750	1070	6-27	965	1045				
	132	250	200	160	100	600	500	200	149	350	475	451	457	870	1570	100	700	490	650	750	1180	6-27	965	1045				
300-350-400	160	250	200									451	508	870	1570	100	700	490	650	750	1180	6-27	965	1045				
	55	300	250									393	349	680	1200	105	620	700	570	670	910	6-27	895	900				
300-350-500	75	300	250	180	100	600	500	200	149	350	425	415	368	720	1260	105	620	750	570	670	960	6-27	895	910				
	90	300	250									415	419	720	1310	100	620	405	570	670	1010	6-27	895	910				

Model	Motor		Pump Overall Dimensions (mm)													Pump set Overall Dimensions (mm)									
	DN1	DN2	A	B	N1	N2	M1	M2	H1	H2	PM	ML	HD	UL	BP	HCL	HC2	HC3	BW	BL	n-BH	H	H3		
300-250-315	75	300	250		180	100	600	500	200	149	350	450	428	368	720	1250	110	670	750	620	720	970	6-27	920	910
	90	300	250		180	100	600	500	200	149	350	450	428	419	720	1305	100	670	410	620	720	1020	6-27	920	910
	110	300	250										459	406	870	1355	100	670	435	620	720	1070	6-27	940	1045
300-250-400	110	300	250										453	406	870	1355	90	700	450	650	750	1080	6-27	1040	1095
	132	300	250		180	100	600	500	200	149	400	500	453	457	870	1600	140	700	450	650	750	1180	6-27	1040	1095
	160	300	250										453	508	870	1600	140	700	450	650	750	1180	6-27	1040	1095
200	300	250											453	508	870	1600	140	700	450	650	750	1180	6-27	1040	1095

Model with 2-pole motor

Model	Motor		Pump Overall Dimensions (mm)													Pump set Overall Dimensions (mm)								
	DN1	DN2	A	B	N1	N2	M1	M2	H1	H2	PM	ML	HD	UL	BP	HCL	HC2	HC3	BW	BL	n-BH	H	H3	
40-32-125	0.75	40	32	80	50	210	160	90	60	115	140	198	100	250	473	65	275	250	230	310	380	4-15	335	365
	1.1	40	32									198	100	250	473	65	275	250	230	310	380	4-15	335	365
40-32-160	1.5	40	32									208	100	260	497	75	305	250	260	340	400	4-15	377	382
	2.2	40	32	80	50	240	190	90	60	132	165	208	125	260	522	65	305	300	260	340	430	4-15	377	382
3	40	32										215	140	280	582	75	305	300	260	340	450	4-15	377	392
	1.1	50	32	80	50	210	160	90	60	115	140	198	100	250	473	65	275	250	230	310	380	4-15	335	365
50-32-125	1.5	50	32									204	100	260	493	70	275	250	230	310	390	4-15	335	365
	2.2	50	32									208	125	260	522	65	305	300	260	340	430	4-15	382	382
50-32-160	3	50	32	80	50	240	190	90	60	132	170	215	140	280	582	75	305	300	260	340	450	4-15	382	392
	4	50	32									222	140	310	582	75	305	300	260	340	450	4-15	382	410
50-32-200	4	50	32									230	140	310	580	80	305	300	260	340	460	4-18	445	438
	5.5	50	32	80	50	240	190	100	70	160	195	254	140	330	637	95	325	300	280	360	490	4-18	445	438
65-50-125	7.5	50	32									254	140	330	637	95	325	300	280	360	490	4-18	445	438
	2.2	65	50	80	50	210	160	90	60	120	150	204	125	260	518	90	275	300	230	310	480	4-15	335	370
65-50-160	3	65	50									211	140	280	593	100	275	300	230	310	500	4-15	335	380
	5.5	65	50									254	140	330	635	90	325	300	280	360	480	4-18	382	410
65-40-200	7.5	65	50	80	50	240	190	100	70	132	170	254	140	330	635	90	325	300	280	360	490	4-18	382	410
	11	65	50									278	210	420	755	90	375	400	330	410	580	4-18	410	500
65-40-250	11	65	40	100	50	265	212	100	70	160	200	278	210	420	775	90	375	400	330	410	580	4-18	440	500
	15	65	40									278	210	420	775	90	375	400	330	410	580	4-18	440	500
65-40-250	15	65	40									278	210	420	775	100	375	400	330	410	600	4-18	485	570
	18.5	65	40	100	50	320	250	125	95	180	225	278	254	420	890	95	375	450	330	410	640	4-18	485	520
22	65	40										291	241	450	872	100	415	450	370	450	650	4-18	485	530

Model	Motor	Inlet flange		Pump Overall Dimensions (mm)																Pump set Overall Dimensions (mm)					
		DN1	DN2	A	B	N1	N2	M1	M2	H1	H2	PM	ML	HD	UL	BP	HC1	HC2	HC3	BW	BL	e-BH	H	H3	
65-40-315	30	65	40									328	305	510	975	100	470	550	420	510	750	4-18	600	650	
	37	65	40	125	65	345	380	125	95	220	260	328	305	510	975	100	470	550	420	510	750	4-18	600	650	
	45	65	40									344	311	550	1035	95	500	600	450	540	790	4-18	605	670	
80-65-160	7.5	80	65									254	140	330	640	90	325	300	280	360	480	4-18	420	438	
	11	80	65	100	50	265	212	100	70	160	180	273	210	420	770	90	385	400	340	420	580	4-18	420	500	
	15	80	65									273	210	420	770	90	385	400	340	420	580	4-18	420	500	
80-50-200	18.5	80	50									282	254	420	835	90	385	450	340	420	630	4-18	445	500	
	22	80	50	100	50	265	212	100	70	160	205	295	241	450	865	95	415	450	370	450	640	4-18	485	530	
	30	80	50									311	305	510	998	90	470	550	420	510	730	4-18	525	630	
80-50-250	30	80	50									323	305	510	975	105	470	550	420	510	760	4-18	550	630	
	37	80	50	125	65	320	250	125	95	180	230	323	305	510	975	105	470	550	420	510	760	4-18	550	630	
	45	80	50									344	311	550	1095	95	510	600	460	550	790	4-18	575	670	
80-50-315	45	80	50									344	311	550	1035	100	500	600	450	540	800	4-18	625	670	
	55	80	50	125	65	345	280	125	95	225	280	368	349	680	1100	100	570	650	520	610	850	4-18	650	800	
	75	80	50									390	368	720	1160	100	625	700	570	680	900	4-22	680	840	
100-80-160	15	100	80									278	210	420	750	100	385	400	340	420	600	4-18	455	500	
	18.5	100	80	100	65	280	212	125	95	160	215	278	254	420	830	100	385	450	340	420	650	4-18	455	500	
	22	100	80									291	241	450	860	100	415	450	370	450	650	4-18	475	530	
100-65-200	22	100	65									306	241	450	875	100	415	470	370	450	670	4-18	485	530	
	30	100	65	100	65	320	250	125	95	180	225	323	305	510	950	105	470	550	420	510	790	4-18	545	630	
	37	100	65									323	305	510	950	105	470	550	420	510	790	4-18	545	630	
100-65-250	45	100	65									344	311	550	1035	105	500	600	450	540	810	4-18	595	670	
	55	100	65	100	65	360	280	160	120	200	250	368	349	680	1100	110	570	650	520	610	870	4-18	620	800	
	75	100	65									390	368	720	1160	110	620	700	570	650	920	4-22	650	840	

Model	Motor	Inlet flange		Pump Overall Dimensions (mm)																Pump set Overall Dimensions (mm)					
		DN1	DN2	A	B	N1	N2	M1	M2	H1	H2	PM	ML	HD	UL	BP	HC1	HC2	HC3	BW	BL	e-BH	H	H3	
100-65-315	75	100	65									400	368	720	1170	110	625	700	570	670	920	4-22	680	840	
	90	100	65	125	80	400	315	160	120	225	280	400	419	720	1220	110	625	750	570	670	970	4-22	680	840	
	110	100	65									436	406	870	1280	100	700	415	650	750	1030	6-22	735	1010	
125-100-200	45	125	100									344	311	550	1035	105	500	600	450	540	810	4-18	625	670	
	55	125	100	125	80	360	280	160	120	200	280	373	349	680	1105	110	570	650	520	610	870	4-18	650	800	
	75	125	100									395	368	720	1165	110	620	700	570	660	920	4-22	680	840	
125-100-250	55	125	100									382	349	680	1130	110	570	650	520	620	870	4-22	660	800	
	75	125	100	140	80	400	315	160	120	225	290	404	388	720	1190	110	625	700	570	670	920	4-22	680	840	
	90	125	100									404	419	720	1240	115	625	750	570	670	980	4-22	690	840	
125-100-315	110	125	100									436	406	870	1405	100	700	415	650	750	1030	6-22	755	1010	
	132	125	100	140	80	400	315	160	120	250	320	436	457	870	1545	100	700	470	650	750	1140	6-22	755	1010	
	160	125	100									436	508	870	1545	100	700	470	650	750	1140	6-22	755	1010	

Note 1: The UL, BL and HC2 sizes in the above table are size coupled with YE3 motor. If other brand motors to be used, the above sizes shall be confirmed by the manufacturer.

2. If BL length is less than 1 meter, HC2 size is a section; if BL is more than 1 meter, then HC2 is two segments of equal length.

Horizontal coupling end suction pump

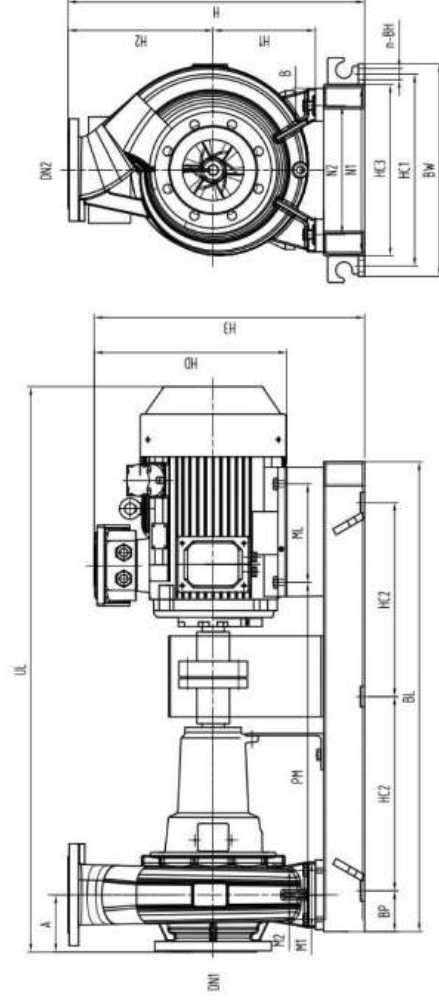

Model with 4-pole motor

Model	Motor		Pump Overall Dimensions (mm)																Pump set Overall Dimensions (mm)							
	Inlet flange	Outlet flange	A	B	N1	N2	M1	M2	H1	H2	PM	ML	HD	UL	BP	HC1	HC2	HC3	BW	BL	n-BH	H	H3			
50-32-200	50	32	80	50	240	190	100	70	160	195	486	100	250	765	100	305	480	260	340	680	4-15	435	410			
	50	32									496	100	260	785	100	305	480	260	340	680	4-15	435	410			
	65	50	80	50	240	190	100	70	132	170	486	100	250	765	100	305	480	260	340	680	4-15	382	382			
65-50-160	65	50	80	50	240	190	100	70	132	170	496	100	260	785	100	305	480	260	340	680	4-15	382	382			

Model	Motor		Pump Overall Dimensions (mm)																Pump set Overall Dimensions (mm)							
	Inlet flange	Outlet flange	A	B	N1	N2	M1	M2	H1	H2	PM	ML	HD	UL	BP	HC1	HC2	HC3	BW	BL	n-BH	H	H3			
65-40-200	65	40	100	50	265	212	100	70	160	200	486	100	260	820	95	325	500	280	360	690	4-15	440	410			
	65	40									513	140	260	845	100	325	520	280	360	720	4-15	440	410			
	65	40									537	140	280	900	100	375	550	280	360	750	4-15	440	420			
65-40-250	65	40	100	50	320	250	125	95	180	225	527	140	280	900	100	375	550	330	410	750	4-15	485	440			
	65	40									635	140	310	1035	100	405	680	360	440	880	4-15	560	498			
	65	40	125	65	345	280	125	95	220	260	674	140	330	1100	100	405	630	360	440	930	4-18	560	498			
80-65-160	80	65									496	100	260	820	95	325	500	280	360	690	4-15	410	410			
	80	65									513	140	260	845	100	325	520	280	360	720	4-15	410	410			
	80	65									513	140	280	900	100	325	550	280	360	750	4-15	420	420			
80-50-200	80	50	100	50	265	212	100	70	160	205	513	140	280	900	100	325	550	280	360	750	4-15	445	420			
	80	50									513	140	280	900	100	325	550	280	360	750	4-15	445	420			
	80	50	125	65	320	250	125	95	180	230	635	140	310	1035	100	385	680	340	420	880	4-15	490	458			
80-50-250	80	50	100	50	265	212	100	70	160	205	674	140	330	1100	100	385	720	340	420	920	4-18	490	458			
	80	50									674	140	330	1100	100	405	720	360	440	920	4-18	585	503			
	80	50	125	65	345	280	125	95	225	280	674	178	330	1120	100	405	760	360	440	960	4-18	585	503			
100-80-315	100	80	125	65	345	280	125	95	275	280	723	210	420	1238	100	405	420	360	440	1040	6-18	585	565			
	100	80									513	140	280	900	100	345	560	300	380	760	4-15	465	420			
	100	80	100	65	280	212	125	95	160	215	513	140	280	900	100	345	560	300	380	760	4-15	465	420			
100-65-200	100	65									628	140	280	1015	100	385	680	340	420	880	4-15	485	440			
	100	65									635	140	310	1025	100	385	680	340	420	880	4-15	485	458			
	100	65	100	65	320	250	125	95	180	225	674	140	330	650	100	385	720	340	420	920	4-18	485	458			
100-65-250	100	65	100	65	360	280	160	120	200	250	674	140	330	1060	100	425	740	380	460	940	4-18	530	478			
	100	65									674	140	330	1060	100	425	740	380	460	940	4-18	530	478			
	100	65	100	65	360	280	160	120	200	250	674	178	330	1123	100	425	790	380	460	990	4-18	530	478			

Model	Motor		Pump Overall Dimensions (mm)													Pump set Overall Dimensions (mm)												
	DN1	DN2	A	B	N1	N2	M1	M2	H1	H2	PM	ML	HD	UL	BP	HC1	HC2	HC3	BW	BL	n-BH	H	H3					
100-65-315	7.5	100	65		125	80	400	315	160	120	225	280		708	178	330	1150	100	465	405	420	500	1010	6-18	585	503		
	11	100	65		125	80	400	315	160	120	225	280		753	210	420	1275	100	465	445	420	500	1090	6-18	585	565		
	15	100	65		140	80	400	315	160	120	225	280		753	254	420	1330	100	465	470	420	500	1140	6-18	585	565		
125-100-200	5.5	125	100		140	80	400	315	160	120	225	280		674	140	330	1095	100	425	740	380	460	940	4-18	560	478		
	7.5	125	100		140	80	400	315	160	120	200	280		674	178	330	1120	100	425	780	380	460	980	4-18	560	478		
	11	125	100		140	80	400	315	160	120	200	280		723	210	420	1245	100	425	430	380	460	1060	6-18	560	540		
125-100-250	11	125	100		140	80	400	315	160	120	225	280		752	210	420	1295	100	465	445	420	500	1090	6-18	595	565		
	15	125	100		140	80	400	315	160	120	225	280		752	254	420	1345	100	465	470	420	500	1140	6-18	595	565		
	15	125	100		140	80	400	315	160	120	250	320		753	254	420	1345	100	470	485	420	510	1170	6-18	680	630		
125-100-315	22	125	100		140	80	400	315	160	120	250	320		766	241	450	1355	100	470	500	420	510	1200	6-18	690	640		
	22	125	100		140	80	400	315	160	120	250	320		766	279	450	1415	100	470	500	420	510	1200	6-18	690	640		
	22	125	100		140	80	400	315	160	120	250	320		761	279	450	1410	100	470	505	420	510	1210	6-18	760	670		
125-100-400	30	125	100		140	100	500	400	200	149	280	360		773	305	510	1440	100	570	525	520	610	1250	6-18	760	710		
	37	125	100		140	100	500	400	200	149	280	360		824	286	550	1490	100	570	540	520	610	1280	6-18	760	725		
	18.5	150	125		140	80	400	315	160	149	250	355		766	241	450	1375	100	470	475	420	510	1150	6-18	725	640		
150-125-250	22	150	125		140	80	400	315	160	149	250	355		778	305	510	1415	100	470	500	420	510	1200	6-18	725	640		
	30	150	125		140	80	400	315	160	149	250	355		778	305	510	1445	100	470	515	420	510	1230	6-18	755	680		
	30	150	125		140	80	400	315	160	149	280	355		923	305	510	1590	100	570	600	520	610	1400	6-18	755	710		
150-125-315	37	150	125		140	100	500	400	200	149	280	355		869	286	550	1560	100	570	610	520	610	1420	6-18	755	725		
	45	150	125		140	100	500	400	200	149	280	355		869	311	550	1665	100	570	625	520	610	1450	6-18	755	725		
	45	150	125		140	100	500	400	200	149	315	400		964	311	550	1670	100	570	630	520	620	1460	6-18	835	760		
150-125-400	55	150	125		140	100	500	400	200	149	315	400		988	349	680	1705	100	570	655	520	620	1510	6-18	835	865		
	75	150	125		140	100	500	400	200	149	315	400		1010	368	720	1850	100	620	680	570	670	1560	6-22	835	875		
	30	200	150		160	100	500	400	200	149	280	375		778	305	510	1465	100	570	525	520	620	1250	6-22	775	710		

Model	Motor		Pump Overall Dimensions (mm)													Pump set Overall Dimensions (mm)												
	DN1	DN2	A	B	N1	N2	M1	M2	H1	H2	PM	ML	HD	UL	BP	HC1	HC2	HC3	BW	BL	n-BH	H	H3					
200-150-315	37	200	150		160	100	550	450	200	149	315	400		824	286	550	1565	100	570	550	520	620	1300	6-22	775	725		
	45	200	150		160	100	550	450	200	149	315	400		824	311	550	1550	100	570	550	520	620	1310	6-22	775	725		
	45	200	150		160	100	550	450	200	149	315	400		964	311	550	1680	100	620	630	570	670	1460	6-22	835	760		
200-150-400	55	200	150		160	100	550	450	200	149	315	400		988	349	680	1795	100	620	655	570	670	1510	6-22	835	865		
	75	200	150		160	100	550	450	200	149	315	400		1010	368	720	1825	100	620	680	570	670	1560	6-22	835	875		
	75	200	150		160	100	550	450	200	149	315	400		1010	368	720	1815	100	620	680	570	670	1560	6-22	885	875		
200-150-500	90	200	150		160	100	550	450	200	149	315	450		1010	419	720	1865	100	620	710	570	670	1620	6-22	885	875		
	110	200	150		160	100	550	450	200	149	315	450		1056	406	870	1932	100	700	730	650	750	1670	6-22	905	1010		
	132	200	150		160	100	550	450	200	149	315	450		1056	457	870	2210	100	700	790	650	750	1780	6-22	990	1070		
200-150-600	160	200	150		180	100	550	450	200	149	375	475		1056	508	870	2210	100	700	790	650	750	1780	6-22	990	1070		
	200	200	150		180	100	550	450	200	149	315	475		1056	508	870	2210	100	700	790	650	750	1780	6-22	990	1070		
	200	200	150		180	100	550	450	200	149	315	475		1056	508	870	2210	100	700	790	650	750	1780	6-22	990	1070		
250-200-250	45	250	200		170	100	550	450	200	149	315	400		833	311	550	1573	100	620	560	570	670	1320	6-22	835	780		
	55	250	200		170	100	550	450	200	149	315	400		853	349	680	1635	100	620	590	570	670	1380	6-22	835	865		
	55	250	200		170	100	550	450	200	149	315	400		998	349	680	1770	100	620	660	570	670	1520	6-22	835	865		
250-200-315	75	250	200		160	100	550	450	200	149	315	400		1020	368	720	1830	100	620	685	570	670	1570	6-22	835	875		
	90	250	200		160	100	550	450	200	149	315	400		1020	419	720	1830	100	620	685	570	670	1570	6-22	835	875		
	90	250	200		160	100	550	450	200	149	315	400		1020	419	720	1880	100	620	710	570	670	1620	6-22	835	875		
250-200-400	110	250	200		160	100	550	450	200	149	350	475		1141	406	870	2040	100	700	780	650	750	1760	6-22	965	1045		
	132	250	200		160	100	550	450	200	149	350	475		1141	457	870	2260	100	700	835	650	750	1870	6-22	965	1045		
	160	250	200		160	100	550	450	200	149	315	475		1141	508	870	2260	100	700	835	650	750	1870	6-22	965	1045		
300-250-250	55	300	250		180	100	600	500	200	149	350	425		1141	508	870	2260	100	700	835	650	750	1870	6-22	965	1045		
	75	300	250		180	100	600	500	200	149	350	425		853	349	680	1660	100	620	590	570	670	1380	6-22	895	900		
	90	300	250		180	100	600	500	200	149	350	425		875	368	720	1720	100	620	610	570	670	1420	6-22	895	910		
300-250-315	90	300	250		180	100	600</																					

Model	Motor		Pump Overall Dimensions (mm)													Pump set Overall Dimensions (mm)							
	DN1	DN2	A	B	N1	N2	M1	M2	H1	H2	PM	ML	HD	UL	BP	HC1	HC2	HC3	BW	BL	n-BH	H	H3
110	300	250									1069	406	870	1965	100	670	740	620	720	1680	6-27	940	1045
	300	250									1143	406	870	1355	100	700	785	650	750	1770	6-27	1040	1095
300-250-400	300	250									1143	457	870	2290	100	700	835	650	750	1870	6-27	1040	1095
	300	250	180	100	600	500	200	149	400	500	1143	508	870	2290	100	700	835	650	750	1870	6-27	1040	1095
200	300	250									1143	508	870	2290	100	700	835	650	750	1870	6-27	1040	1095

Model with 2-pole motor

Model	Motor		Pump Overall Dimensions (mm)													Pump set Overall Dimensions (mm)							
	DN1	DN2	A	B	N1	N2	M1	M2	H1	H2	PM	ML	HD	UL	BP	HC1	HC2	HC3	BW	BL	n-BH	H	H3
40-32-125	40	32	80	50	210	160	90	60	115	140	468	300	250	743	100	275	460	230	330	660	4-15	335	365
	40	32									478	300	250	753	100	275	460	230	330	660	4-15	335	365
40-32-160	40	32									488	300	260	777	100	305	480	260	340	880	4-15	377	382
	40	32	80	50	240	190	90	60	132	165	488	325	260	802	100	305	510	260	340	710	4-15	377	382
3	40	32									505	340	280	872	100	305	540	260	340	740	4-15	377	392
	50	32									478	300	250	753	100	275	460	230	310	660	4-15	335	365
50-32-125	50	32	80	50	210	160	90	60	115	140	484	300	260	773	100	275	470	230	310	670	4-15	335	365
	50	32									488	325	260	802	100	305	510	260	340	710	4-15	382	382
50-32-160	50	32	80	50	240	190	90	60	132	170	505	340	280	872	100	305	540	260	340	740	4-15	382	392
	50	32									512	340	310	872	100	305	540	260	340	740	4-15	382	410
50-32-200	50	32									520	340	310	870	100	305	550	260	340	750	4-18	445	438
	55	32	80	50	240	190	100	70	160	195	559	340	330	942	100	325	600	280	360	800	4-18	445	438
65-50-125	50	32									559	340	330	942	100	325	600	280	360	800	4-18	445	438
	65	50	80	50	210	160	90	60	120	150	484	325	260	798	100	275	560	230	310	760	4-15	335	370
3	65	50									501	340	280	842	100	275	590	230	310	790	4-15	335	380
	65	50									559	340	330	940	100	325	590	280	360	790	4-18	382	410
65-50-160	65	50	80	50	240	190	100	70	132	170	559	340	330	940	100	325	590	280	360	790	4-18	382	410
	65	50									608	210	420	1085	100	375	710	330	410	910	4-18	410	500
65-40-200	65	40	100	50	265	212	100	70	160	200	608	210	420	1105	100	375	710	330	410	910	4-18	440	500
	65	40									608	210	420	1105	100	375	710	330	410	910	4-18	440	500
65-40-250	65	40									608	210	420	1105	100	375	730	330	410	930	4-18	485	520
	65	40	100	50	320	250	125	95	180	225	608	254	420	1160	100	375	760	330	410	980	4-18	485	520
22	65	40									621	241	450	1200	100	415	760	370	450	980	4-18	485	530

Model	Motor	Inlet flange		Pump Overall Dimensions (mm)													Pump set Overall Dimensions (mm)							
		DN1	DN2	A	B	N1	N2	M1	M2	H1	H2	PM	ML	HD	UL	BP	HC1	HC2	HC3	BW	BL	n-BH	H	H3
65-40-315	30	65	40	125	65	345	280	125	95	220	260	753	305	510	1400	100	470	490	420	510	1180	6-18	600	650
	37	65	40	125	65	345	280	125	95	220	260	753	305	510	1400	100	470	490	420	510	1180	6-18	600	650
	45	65	40	125	65	345	280	125	95	220	260	764	311	550	1455	100	500	510	450	540	1220	6-18	605	670
80-65-160	7.5	80	65	100	50	265	212	100	70	160	180	603	210	420	1100	100	385	710	340	420	910	4-18	420	500
	11	80	65	100	50	265	212	100	70	160	180	603	210	420	1100	100	385	710	340	420	910	4-18	420	500
	15	80	65	100	50	265	212	100	70	160	180	612	254	420	1165	100	385	770	340	420	970	4-18	445	500
80-50-100	18.5	80	50	100	50	265	212	100	70	160	205	625	241	450	1195	100	415	770	370	450	970	4-18	465	530
	22	80	50	100	50	265	212	100	70	160	205	625	241	450	1195	100	415	770	370	450	970	4-18	465	530
	30	80	50	100	50	265	212	100	70	160	205	636	305	510	1360	100	470	430	420	510	1060	6-18	525	630
80-50-250	30	80	50	125	65	320	250	125	95	180	230	748	305	510	1400	100	470	500	420	510	1200	6-18	550	630
	37	80	50	125	65	320	250	125	95	180	230	748	305	510	1400	100	470	500	420	510	1200	6-18	550	630
	45	80	50	125	65	320	250	125	95	180	225	764	311	550	1455	100	510	510	460	550	1220	6-18	575	670
80-50-315	55	80	50	125	65	345	280	125	95	225	280	813	349	680	1545	100	570	550	520	610	1300	6-18	650	800
	75	80	50	125	65	345	280	125	95	225	280	813	349	680	1545	100	570	550	520	610	1300	6-18	650	800
	100	80	50	125	65	345	280	125	95	225	280	835	368	720	1605	100	625	575	570	680	1350	6-22	680	840
100-65-160	15	100	80	100	65	280	212	125	95	160	215	608	210	420	1080	100	385	400	340	420	930	4-18	455	500
	18.5	100	80	100	65	280	212	125	95	160	215	608	254	420	1160	100	385	450	340	420	980	4-18	455	500
	22	100	80	100	65	280	212	125	95	160	215	621	241	450	1190	100	415	450	370	450	980	4-18	475	530
100-65-200	22	100	65	100	65	320	250	125	95	180	225	736	241	450	1305	100	415	450	370	450	1100	6-18	485	530
	30	100	65	100	65	320	250	125	95	180	225	748	305	510	1375	100	470	510	420	510	1220	6-18	545	630
	37	100	65	100	65	320	250	125	95	180	225	748	305	510	1375	100	470	510	420	510	1220	6-18	545	630
100-65-250	45	100	65	100	65	340	280	160	120	200	250	764	311	550	1455	100	500	515	450	540	1230	6-18	595	670
	55	100	65	100	65	340	280	160	120	200	250	813	349	680	1545	100	570	560	520	610	1320	6-18	625	670
	75	100	65	100	65	340	280	160	120	200	250	835	368	720	1605	100	620	590	570	650	1380	6-22	650	840

Model	Motor	Inlet flange		Pump Overall Dimensions (mm)													Pump set Overall Dimensions (mm)							
		DN1	DN2	A	B	N1	N2	M1	M2	H1	H2	PM	ML	HD	UL	BP	HCL	HCE	HCE3	BW	BL	n-BH	H	H3
100-65-315	75	100	65	125	80	400	315	160	120	225	280	865	368	720	1635	100	625	600	570	670	1400	6-22	680	840
	90	100	65	125	80	400	315	160	120	225	280	865	419	720	1685	100	625	625	570	670	1450	6-22	680	840
	110	100	65	125	80	400	315	160	120	225	280	881	406	870	1735	100	700	650	650	750	1500	6-22	735	1010
125-100-200	45	125	100	140	80	360	280	160	120	200	280	764	311	550	1455	100	500	515	450	540	1230	6-18	625	670
	55	125	100	140	80	360	280	160	120	200	280	818	349	680	1550	100	570	560	520	610	1320	6-18	650	800
	75	125	100	140	80	360	280	160	120	200	280	840	368	720	1610	100	620	600	570	660	1400	6-22	680	840
125-100-250	55	125	100	140	80	400	315	160	120	225	290	869	368	720	1655	100	625	600	570	670	1400	6-22	680	840
	75	125	100	140	80	400	315	160	120	225	290	869	419	720	1705	100	625	625	570	670	1450	6-22	680	840
	90	125	100	140	80	400	315	160	120	225	290	891	406	870	1860	100	700	650	650	750	1500	6-27	755	1010
125-100-315	132	125	100	140	80	400	315	160	120	250	320	891	457	870	2000	100	700	700	650	750	1600	6-27	755	1010
	160	125	100	140	80	400	315	160	120	250	320	891	508	870	2000	100	700	700	650	750	1600	6-27	755	1010
	180	125	100	140	80	400	315	160	120	250	320	891	508	870	2000	100	700	700	650	750	1600	6-27	755	1010

Note 1. The UL, BL and HC2 sizes in the above table are size coupled with YE3 motor. If other brand motors to be used, the above sizes shall be confirmed by the manufacturer.

2. If BL length is less than 1 meter, HC2 size is a section; if BL is more than 1 meter, then HC2 is two segments of equal length.

Pump flange dimensions

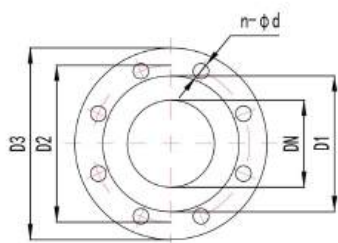

Flange dimensions					
DN	D1	D2	D3	n	d
32	76	100	140	4	18
40	84	110	150	4	18
50	102	125	165	4	18
65	122	145	185	4	18
80	133	160	200	8	18
100	158	180	220	8	18
125	184	210	250	8	18
150	212	240	285	8	22
200	268	295	340	12	22
250	320	355	405	12	26
300	370	410	460	12	26

Installation & maintenance

Installation requirements

1. Use the secondary grouting method for installation. Make the concrete foundation according to the base size, and bury the anchor bolts. The installation base should be level.
2. The pump and motor should be checked before installation:
 - All parts should be free of damage, and there should be no debris in the pump;
 - The model and parameters of the pump and motor should be correct;
 - The technical data and quality certificates should be complete.
3. An expansion joint should be set between the suction and discharge pipe of the pump and the pump to compensate for the alignment error, and to isolate the vibration of the pump body and the pipe;
4. In order to prevent debris from entering the pump, it is recommended that a filter should be set at the inlet, and the filtration area should be 3 to 4 times greater than the cross-sectional area of the pipeline;
5. The pump with high head and the pump running in parallel should also be installed on the outlet pipe to prevent the water hammer damage of sudden stop;
6. It is necessary to ensure that the installation height of the pump is in line with the cavitation allowance of the pump, and consider the pipeline loss and medium temperature.

Attentions

Preparation of concrete:

We recommend to use the concrete as shown by below drawing, to ensure the best stability of the pump set.

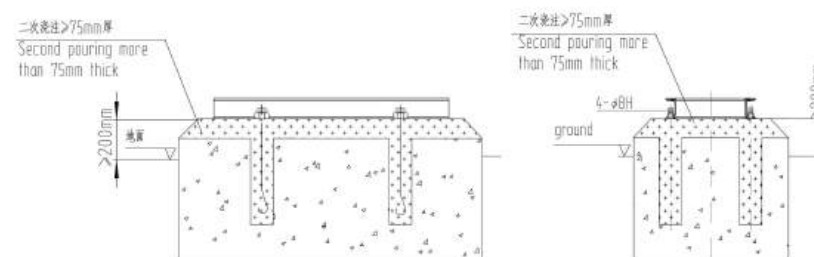

Alignment of the coupling of 3S pump:

After the 3S pump unit is installed on the base, the alignment of the coupling must be readjusting, that is, placing a flat ruler on the coupling to check whether the shaft line of the pump and the shaft line of the motor coincide. If the level does not coincide, slightly move the pump foot and motor foot; If the vertical does not coincide, the foot of the motor or the foot of the pump is covered with a thin iron sheet, so that the two couplings are round and flat, and then take out the thin iron sheet of the pad, replace the iron sheet with a processed iron block, and finally re-check the installation.

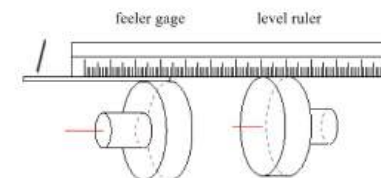

In order to check the precision of the installation, measure the gap between the planes of the two shaft couplings on a few opposite positions (0 and 6 o'clock, 3 and 9 o'clock) with feeler gage. The difference of the maximum and minimum radial gaps all around the plane must not exceed 0.3 millimeter, while the horizontal and vertical differences of the maximum and minimum axial gaps ($\Delta=81-83$ for vertical difference, $\Delta=82-84$ for horizontal difference) of both ends' centerlines must not exceed 0.1 millimeter.

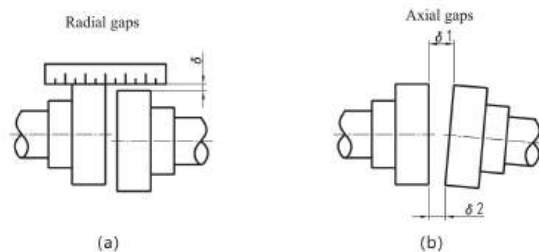

Start&Run

1. Before starting, the pump should be filled with the delivered liquid (if it is sucked on) close the outlet valve and connect the power line;
2. Turn on the power and check whether the steering of the pump is correct, as shown in the direction of the sign;
3. Trial test run 5~10 minutes, if no abnormal phenomenon can be put into operation;
4. When stopping, the exit gate valve should be closed first, and then cut off the power supply;
5. When disassembling, first flush the flow channel of the pump with clean water until the debris in the pump is completely washed;
6. When replacing the parts of the pump, do not hit the parts with sharp objects or hard objects, and gently tap the wood wrapped in a soft cloth. The removed parts should be handled lightly with the sealing surface facing up.
7. During use, often check the pump and motor. If abnormal noise or temperature rise is found, it should be stopped immediately for maintenance.

Typical malfunctions with Trouble shootings

Malfunctions	Possible Reasons	Solutions
No water come from pump when starting	There is residual air in suction pipeline or pump housing.	Open the exhaust valve, refill the water, and expel the air.
	Air leakage in suction pipeline.	Inspect and adjust suction pipelines, tighten seal faces, expel the residual air.
	Either suction or discharge valves are closed or pipelines are blocked.	Open suction and discharge valves or clean the pipelines.
	The motor rotates inversely or slowly, lacks phase.	Alternate the rotating direction of the pump; Tighten the motor wiring.
	The mounting height is too high.	Lower mounting height.
	Suction pressure is so low that cavitation happens. Bottom valve leaks out.	Stop the pump to check and adjust the suction pressure. Repair or replace the bad bottom valve.
The capacity of pump is insufficient.	The resistance of discharge pipeline is too large or geometric height is too high. Improper pump selection, excessively lower head than needed.	Bold discharge pipeline or reduce the corners number. Re-select the pump.
	Firstly check the causes of above malfunction 1.	Firstly to solve by malfunction 1.
	Impellers are worn-out	Replace impellers.
	Rotating speed of pump or power voltage is far below the required value.	Check the motor and remain stable power voltage supply.
	Impeller flow channels, discharge pipelines or suction pipelines are blocked by the scale.	Clean impellers and pipeline.

Malfunctions	Possible Reasons	Solutions
	The discharge valve opens less than required.	Turn up the discharge valve.
Motors overload	The flow rate exceeds allowable range.	Turn down the discharge valve to adjust the flow rate.
	There are mechanical frictions somewhere.	Check and locate frictions, prepare for maintenance.
Motors overload	The flow rate exceeds allowable range. The motor is overloaded.	Turn down the discharge valve.
	The rotar scratches.	Check and remove.
	Bearings are worn out.	Replace worn bearings.
	Power voltage is insufficient.	Remain stable power voltage supply.
Pumps make noise and vibrate violently.	Cavitation happens.	Turn down the discharge valve. Bring down height of installation. Lower the resistance of suction pipeline.
	The impeller single vane is congested.	Clean the impellers.
	Fastening parts or foundation becomes flexible.	Fasten anchor nuts and reinforce the foundation.
	There are mechanical frictions somewhere.	Check and locate frictions, prepare for maintenance.
The pump leaks out: shaft end leakage, pump shell leakage, the seal faces leakage	Shaft end seal clearance is too large.	Replace wear rings.
	Mechanical seal dynamic and static rings are worn out, spring pressure is too light.	Repair or replace the worn material, adjusting the spring.

Malfunctions	Possible Reasons	Solutions
(including mechanical seal)		Turn up the discharge valve.
	Uneven seal faces fit poor (including echanical seal dynamic and static rings).	Repair the seal faces flat (including echanical seal dynamic and static rings).
	The pump shell has sand holes or cracks.	Weld repair the defects or replace a new shell.